



# Installing an MSDI Skipline Control with an Allison World Transmission

## GENERAL

MSDI Skipline Controls and Precision Speedometers may be operated by the speed output signal from an Allison World Transmission. The speed sender output of the Allison transmission electronic control unit (ECU) is an SAE standard J-1809 square wave. The speed signal input (sender input) of the MSDI control is compatible with this standard without any accessory adapters. Do NOT use the internal transmission sender. The SA1 Sender Adapter is not needed for this installation.

## WIRING

The Power and Solenoid connection of the Control should be wired in accordance with the wiring chart provided in the Instruction Manual. The Sender branch of the cables must be wired as shown in the figure. Wire 157 is available in both of the vehicle interface module (VIM) connectors, at pin B2 on the 18-pin connector, or pin H2 on the 30 pin connector. You may need to contact your dealer for details of your specific transmission installation. The wire color is commonly violet or tan.

Insulate and tie back the RED sender cable wire. It is not used in this installation and must be protected from shorts to other wires and to ground.

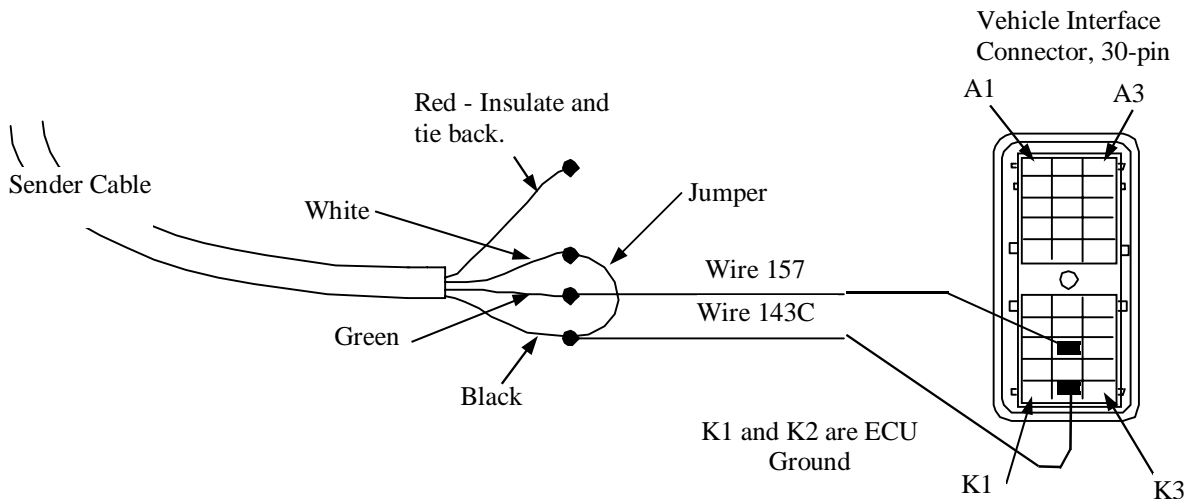

## OPERATION

Calibration of the system is carried out exactly as described in the instruction manual for the controller. If you have a two-speed rear axle, be sure to perform the calibration using the same ratio that you will use for painting.