

Instruction Manual..

MODEL CS11A SKIPLINE CONTROLLER Version 3.1

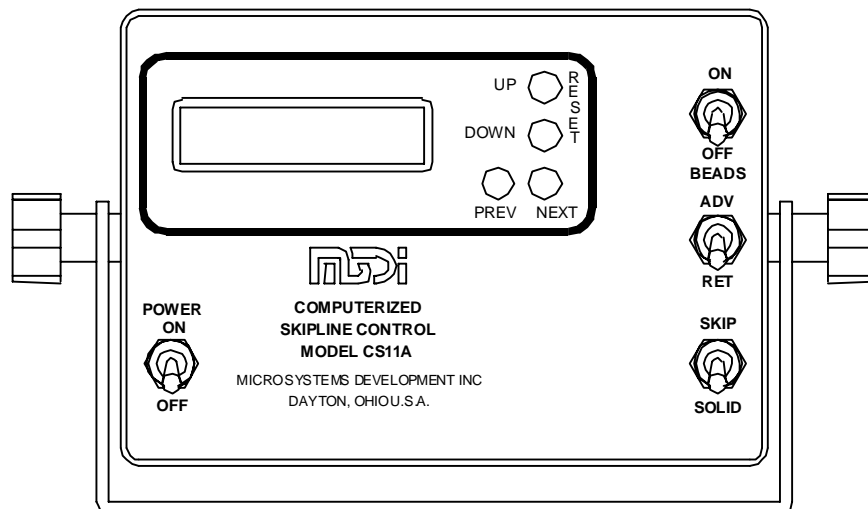

Micro Systems Development Inc.
46 Marco Lane
Dayton, Ohio 45458

Copyright © 1997 Micro Systems Development Inc.
All rights Reserved.

TABLE OF CONTENTS

1	INTRODUCTION.....	5
2	INSTALLATION.....	6
	Preliminary Steps	6
	Control Unit Installation	7
	Solenoid Valve Installation	7
	Sender Installation	7
	Battery Installation.....	8
	Plumbing.....	8
	Wiring.....	8
3	THE CS11A CONTROL PANEL	10
	Testing your installation	10
4	SETTING UP THE CS11A.....	13
	Sender Calibration	13
	Beads Distance Delay Timer	15
	Setting Paint Delay Timer	15
	Beads Delay Timer	17
5	OPERATION	19
	Controls	19
	Basic Striping.....	20
	Repainting Old Lines.....	20
	Using Fast Edit.....	20
	Using Cycle-Track.....	20
	Using Cycle-Lock.....	20
	Layouts	22
	Setting up the Layout System	22
	Setting up the Layout for Remarkings	23
6	BATTERY MAINTENANCE.....	24
	If You Have an Electric Start Striper	24
7	BUILT-IN TEST PROGRAM.....	25
8	TROUBLESHOOTING	26

CONGRATULATIONS!

You have purchased the most advanced skipline controller available for portable striping machines.

Take time to read through the installation and operation guides before you begin installing your system. By doing this, you will find the installation is easier, neater, and more convenient. Because every striping machine is different, you may have to modify and adapt these instructions to fit your particular machine.

You will be installing a Control Unit, one or more solenoid operated air valves, a footage sender unit, and perhaps a battery.

We will use the  symbol to indicate important

information that relates to the safety or function of your equipment. **Be sure to read these notices carefully!**



WARNING

INJECTION HAZARD

Be sure to release paint system pressure before working on system. CONTROLLER MAY TURN THE GUNS ON WITHOUT WARNING.



CAUTION

NEVER arc weld on your machine with the controller connected! SEVERE damage to the controller can result!

PRELIMINARY STEPS

Look over your machine. See where the best location would be for the Control Unit. Generally, you will be using the Skip/Solid switch most often, so it's most convenient to locate the unit over the right handgrip so that the switch is closest to your fingers or thumb. This is especially true of right delivery machines. On left delivery machines, you might want to consider locating the Control Unit over the left handgrip.

Check the location of the paint gun. The solenoid valve should be located on the same side of the machine as the gun to keep the control air hose short. If your machine permits the gun to be moved from one side to the other, the solenoid should perhaps be mounted centrally, so that the same control hose will reach the gun on either side. Verify that the control box cable will reach from the control box to the solenoid.

Check the documentation for your painting machine to determine the maximum allowable control pressure to the guns. The standard valves for the CS11A controllers require a minimum of 50 PSI to operate dependably. If this pressure exceeds the allowable control pressure for your guns, you should use the B901022A valves instead. These valves require only 30 PSI. If your control pressures are over 150 PSI, you must install a regulator to reduce the pressure to something below 150 PSI.

The sender assembly (the sender, pickup wheel and bearing) should be located so that the pickup wheel rides on the top tread surface of one of the large tires. Don't mount the sender on the front caster tire as it often loses contact with the pavement. Also, don't install the sender so that the wheel rides on the sidewall of a tire. Most machines have so much sideways vibration that the sender wheel will scrub against the sidewall and may turn even while the machine is standing still. In any event, the sender wheel will not accurately sense the motion of the machine. This is not a problem with the wheel in contact with the top tread surface of a one of the large tires.

The battery box can be mounted in any convenient location. Be sure to allow enough clearance so that the battery can be removed and replaced easily. The battery and case together weigh about seven pounds, so be sure that the mounting is sturdy. Of course, if your machine has a 12-volt electric starter and a charging system, you will want to use your existing battery and will not need to install another one.

CONTROL UNIT INSTALLATION

The Control Unit is supplied with a mounting yoke that mounts conveniently to the crossbrace between the handlebars. If your striper doesn't have a crossbrace you may want to add one. Otherwise, you can fabricate a bracket to be welded or mounted to one handlebar to support the controller. Be sure that the mounting is sturdy enough to hold the controller in place while you operate the switches. SEE THE BOX ON PAGE 3 REGARDING WELDING!

The cable and connector are mounted on the rear panel of the controller. Be sure that you allow enough clearance so you can adjust the controller for a comfortable mounting angle.

SOLENOID VALVE INSTALLATION

The Solenoid Valve should be mounted to a metal plate or to individual mounting clamps (Appleton clamps) in the vicinity of the gun. The valve will be connected to two wires of the 5-conductor branch of the control box cable. The center port (Port #1) of the valve should be connected to the main air line, with a pressure of at least 50 PSI. (30 PSI for B901022A valves). The output port (Port #4) of each valve will connect through a flexible hose to the control port of each of the guns. The exhaust ports must remain open. Refer to the Wiring Diagram and Plumbing Diagram for further information on installation of the valves.

SENDER INSTALLATION

The footage sender installation is the most critical part of installing the CS11A system. A poor mounting method will result in inaccurate and inconsistent line and cycle lengths.

The footage sender assembly must be mounted so that it rides firmly on the tread surface of one of the large wheels. The sender assembly may be mounted from a movable arm and held against the tire with a spring, or it may be rigidly mounted in contact with the tire. In any event, be sure that the sender pickup wheel doesn't fall into a groove in the tread. It must consistently ride on the outer surface of the tread. See Fig. 5 for two mounting suggestions.

BATTERY INSTALLATION

If you have a striper with an electrical system, you can ignore this section.

The battery box can be installed wherever convenient. Just be sure that you allow room for the lid to open fully, and that you can remove and replace the battery without interference. If the mounting holes provided are not properly located for your machine, feel free to drill additional ones. To avoid cracks in the battery case, make sure that the mounting bolt heads do not touch the battery itself.

PLUMBING

Connect the air output port on the solenoid valve to the control input port on the paint gun using appropriate high pressure rubber hose. Use joint compound or joint tape on all connections. Connect the solenoid valve input port to the main pressure line on your machine. This plumbing may be done with 1/4 inch copper tubing and flare fittings. Because of the vibration common to these machines, allow plenty of slack in the tubing in the form of U's and loops. You should also provide a master valve in this line to allow the control air to be shut off. The valves provided by MSDI do not require any filtering or lubrication of the air so no additional components will be needed. Do not obstruct the exhaust ports on the valves. The air in the guns must be free to exhaust quickly to assure uniform line lengths.

WIRING

Refer to the wiring diagram in this manual for color codes.

Install the controller cable using the supplied tie-wraps. When installing the cable, make sure that you provide enough slack for adjustment of the controller unit and enough slack elsewhere so that none of the cables or wires are placed under any tension or strain. Don't connect the cable connector to the controller unit just yet. Route the cables so that they will not contact the engine, engine muffler or the compressor, or be in the direct path of the hot exhaust gasses from the engine.

Connect the solenoid wires from the 5-conductor branch of the cable to the solenoid terminals according to the wiring diagram. The common wire (red) can connect to either solenoid terminal, and

the signal wire (green, white, orange, brown or black) will then connect to the other terminal.

Connect the sender wires to the 4-conductor branch of the cable. If you are using the zero-speed sender, connect three wires, red to red, white to green and black to black. Use crimp-on butt splice connectors or fully insulated push-on tab terminals to join the sender wires to the cable wires. The white wire from the cable should be connected to the black wire. If you are using the near-zero-speed sender, connect the two wires from the sender to the green and white wires in the cable. It doesn't matter which sender wire you connect to the green or white cable wires, just be sure to use only the green and white wires from the cable. Individually insulate the unused red and black wires from the cable. If they touch each other or the machine frame, the fuse in the Control Unit will blow.

Connect the battery cable to the battery. If you are using the battery box, there will be a cable coming out of the box. Connect red to red and black to black.



WARNING

Do not let the battery terminals short out. SEVERE damage to the battery will result! The battery is not intended for engine starting. Do not attempt to charge the battery with a standard automotive battery charger as battery life will be seriously shortened. Use only a charger specifically designed for Gel-Cell batteries.

If you are using the electrical system on your striper for power, check the instruction manual for your striper to determine the best place to obtain 12 volts from the electrical system. Appropriate 0.250 inch tab terminals may be procured locally to connect to the striper's electrical system. Be sure that the polarity of the wires is correct, red is positive, black is negative (grounded).

THE CS11A CONTROL PANEL

Now is a good time to examine the control panel to see what the various switches do.

The panel has **four** toggle switches that are ordinarily used to operate the CS11A and four pushbuttons that are used only for setting up the skipline and matching the controller to your machine.

The POWER switch controls the battery power to the controller and to the gun solenoids.

The BEADS switch controls the application of beads to the paintline. When the PAINT switch is set to SKIP, the beads will be automatically switched on and off with the paint guns, with time and distance delays to assure full coverage.

The ADVance/RETard switch shifts the position of the skip cycle about one foot for each second that it is held. ADVance will make the paint and/or cycle longer, RETard will make them shorter.

The PAINT switch (SKIP-SOLID) controls the paint gun. This switch is OFF in the center position. When pushed upward, the gun will paint a skipline with the cycle and paint lengths displayed on the LCD screen. When pushed downward, the gun will paint a solid line.

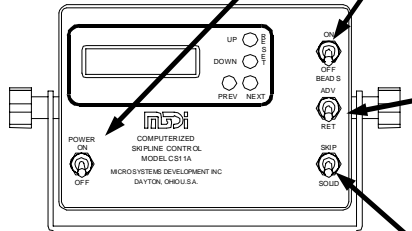

TESTING THE INSTALLATION

Now that the system is wired and plumbed and you are familiar with the controls, we will check out the controller wiring and also get some practice with the switches and the display on the Control Unit. Don't start the engine yet.

Make sure that the POWER switch on the Control Unit panel is turned OFF. Attach the circular cable connector to the Control Unit. Be sure that the connector is firmly seated in the receptacle on the back of the Control Unit. Set the SKIP-SOLID switch to OFF (center position).

Turn the POWER switch ON. The display should "sign-on" with the manufacturer's name, then the model number of the controller. After a few seconds, the display will switch over to the "MAIN DISPLAY". If you don't see the "sign-on", carefully recheck the battery connections. Make sure the battery leads are not

reversed. Also, make sure that the battery is charged.

The contrast of the display can be adjusted (ONLY when showing the "MAIN DISPLAY") by pressing the UP or DOWN buttons to the right of the display. There are eight levels of contrast, one of them is sure to be "just right." The appearance of the display is affected by the viewing angle, so position the controller as it will be while you are using the machine. Adjust the contrast now for the clearest display from your normal operating position. The contrast setting will be saved and recalled the next time you turn the controller on.

At the left side of the display you will see the default PAINT and CYCLE lengths in feet. In the upper right corner you will see the current speed, in miles-per-hour. It will read 0.0 unless the striper is moving. In the lower right corner you will see a star (asterisk). This star will blink on and off as sender pulses are received. This star is also the battery low indicator. When the battery begins to run down, the star will change to a "B". This is a warning that the battery needs to be charged soon. Immediately to the left of the star is a "P". This "P" appears when the Control Unit is in the Paint portion of the cycle, and disappears while in the Skip portion of the cycle.

Roll the striper a few feet forward and backward. You should see the star blink on and off as the sender wheel turns. If the star doesn't blink, carefully check the wiring and terminals where the sender connects to the Control Unit cable. Make sure all connections are tight and that the color codes are correct. Make sure that the drive tang (a small square shaft) is installed in the bearing assembly to couple the rotation of the wheel to the sender shaft.

When power is first turned on, the CS11A puts itself in HOLD mode to prevent accidental release of paint in case the PAINT-SKIP switch was left on. As soon as you move the SKIP-SOLID switch to OFF (center) position, the automatic HOLD is removed. Now, pushing the switch to either position will cause the gun to paint.

Put your ear close to the paint solenoid valve and turn on the SOLID switch. You should hear the valve click.

If you didn't hear the clicks from the solenoid, repeat the above solenoid test, but this time watch the display on the controller. If the solenoid circuit is open or shorted, the display will tell you. Short circuits will be indicated as you turn the SKIP-SOLID switch to SOLID. Open circuits will be indicated as you turn the SKIP-SOLID switch off (center position). If the display indicates a

problem with the solenoid, recheck the connections to that solenoid. If the problem is an open circuit, especially check that the push-on terminals are properly crimped to the cable wires. If a short is indicated, look for pinched or abraded wires shorting to each other or to the machine frame.

This completes the preliminary tests. The next step is to calibrate the sender to your machine and set the delays.

SETTING UP THE CS11A

In this section, we will be using the CS11A menu system to configure the CS11A to match your painting machine. All of the settings you make here will be saved in a special memory in the Control Unit and will not have to be re-entered again unless you change the configuration of your machine (such as to recalibrate, etc.) Refer to the two MENU CHARTS later in this manual to see how the menus are organized and to see how to get from one menu to another.

SENDER CALIBRATION

The Model CS11A incorporates an automatic calibration feature which allows accurate operation with anything from about 0.08 to 15 sender pulses per foot. This makes it unnecessary to perform difficult and time consuming sender position adjustments to achieve good accuracy. The Sender Calibration procedure adjusts the CS11A to your sender, pickup wheel and tire size or to your vehicle speedometer system if you are using the transmission signals.

You will need to tape off an exact distance of 100 feet in your parking lot, driveway or other suitable place. Measure this distance carefully, as an error here will be reproduced in every skipline you paint. If you prefer to calibrate in meters, set the controller to metric and measure off a distance of 30.5 meters. Substitute this distance for 100 feet in the following instructions. **No recalibration is necessary when changing from English to metric units.** Calibrating in English automatically calibrates metric and vice versa.

Roll your machine to one end of the marked 100 foot path. Carefully line up some part of the machine with the mark indicating the beginning of the 100 feet. A good point to line up on is the center of the tread “footprint” of the tire that drives the sender if applicable or the rear tire nearest the left paint carriage.

Press NEXT repeatedly until you see “SETUP MACHINE?”. Press UP for yes. The display will show “SET SENDER RATIO?”. Press UP for yes. The display will show

“SENDER PULSES XX” with the current setting instead of ‘XX’. The value set here will determine how the CS11A reads the signals from the sender. Start with this value set to ‘X1’ so that the CS11A will read only one count for each pulse. When you do the rolling calibration next, if you don’t get enough pulses, come back to this menu and set the value to a higher value, then repeat the rolling calibration.

Press NEXT and the display will show “CALIBRATE SENDER?”. Press UP for yes. The display will ask “ADJUST VALUE?”. Press DOWN for no. The display will say “PUSH ADV, ROLL 100 FEET.”

Recheck that you are lined up on the mark, then momentarily press the ADV switch. Roll the machine to the other mark at the end of the 100 foot path, stopping carefully on the mark. Don't let the machine roll backwards. Then press ADV again. The display will show the actual number of pulses from the sender. Write this number down. The display will then say “ADJUST VALUE?”. Press DOWN for no, then press NEXT to store the new count value. If the count was between 510 and 5000, the CS11A is now calibrated. If you got more than 5000 pulses, you will have to replace your sender with one with a lower pulse rate. If you didn't get at least 510 pulses, you will need to increase the Sender Ratio. Calculate the new Sender Ratio by dividing 1000 by the number of pulses, and set the Sender Ratio to the closest number. For instance, if you got 33 pulses, divide 1000 by 33. The answer is 30.303. The closest Sender Ratio is 32, so set the sender ratio display to SENDER PULSES X32. Now, repeat the rolling calibration and your pulses should be between 750 and 1500 pulses. You may want to set the Sender Ratio one step higher if you got under 750 pulses.

For even greater accuracy, repeat the 100 foot roll several times, writing down the count values each time. The count values should all be very close to each other, not more than one or two counts off. Now, average the count values. To do this, add up the count values, then divide the result by the number of values that you added. Write down the result of this division, this is the average of all the count values. Enter the SETUP MACHINE menu and go to “CALIBRATE SENDER” and then to the “ADJUST VALUE?” display. This time, press UP for yes. The current count value will be displayed. Using the UP and DOWN buttons, adjust the value shown to the average count value you got from your calculation above. When you are finished, press NEXT and the new value you entered will be stored in the CS11A.

To check your calibration, roll the machine to the end of the 100 foot path. Line up the machine with the mark. Display the TOTAL

FOOTAGE counter and reset it to zero by pressing UP and DOWN simultaneously. Roll the machine to the other end of the path and then read the counter. The counter should read 100.0 feet. If it doesn't, repeat the calibration or manually adjust the Calibration Value.

If you get the message "CALIBRATION BAD...CALIBRATION CANCELED", it indicates that the CS11A either received too many or not enough pulses. The actual pulses received will be indicated on the display. Read this number, and if it is over 5000 go back to the SENDER RATIO menu and set it to a lower number. If it's already at X1, you will have to modify your sender to reduce the pulse rate. If the pulse count is under 510, go back to the SENDER RATIO menu and set it to a higher number. If the Sender Ratio is already at X64, you will have to modify your sender to increase the pulse rate. In either case, you will have to repeat the rolling calibration after you change the sender ratio. As a goal, try to calibrate for 750 to 1500 pulses. This provides the best mix of accuracy and speed.

If you are calibrating with a Sender Ratio of X4 or higher, try to do the rolling calibration "on-the-fly" while travelling at your normal striping speed to get the best accuracy. You can always "trim up" the calibration later when you are painting.

To check for the effects of vibration on the sender, repeat the 100 foot test of the preceding paragraph, this time with the engine running at normal speed. The footage counters should read 100 feet again. If the footage counter reads over 100 feet, it generally indicates that the sender mounting is vibrating excessively and creating extra pulses. If the count is under 100 feet, the pickup wheel may be slipping against the tire. Correct the problem with the sender before proceeding further.

SETTING DELAY TIMERS

The delay timers are used to compensate for the time it takes for the air pressure to build and exhaust in the control lines and the guns.

BEADS DISTANCE DELAY

Measure the distance between the point at which paint strikes the pavement to the point at which the beads hit the pavement. (This is NOT necessarily the same as the spacing between the gun nozzles.) Go to the "SET DELAYS" menu and select "BEAD GUN DIST". Using the UP and DOWN buttons, adjust the value to the distance you just measured. Press NEXT to store the

value.

PAINT DELAY TIMER

Re-enter the “SET DELAYS” menu and make sure that all four timers are set to zero.

Go to the “SETUP SKIPLINE” menu and set the PAINT for 10 feet and the CYCLE for 20 feet. Set the gun switch to OFF.

Start the engine and set all the pressures to their normal values.

Switch the gun switch to SKIP position and paint three paint/skip cycles at your normal striping speed. While you are painting, take note of the speed indicated on the speedometer.

Measure the length of the second paint/skip cycle from the beginning of the second paint line to the beginning of the third paint line. This distance must be 20 feet. If it isn't, recheck the Sender Calibration as described above. If the Sender Calibration checks out OK, you should check your paint gun to make sure that the mechanism is not sticking or operating sluggishly and that the orifice is clean.

Now measure the length of the second paint line. The goal here is to make the paint line exactly 10 feet long. If the line is too long, you will have to insert some paint-on delay, and if the line is too short, you will have to insert some paint-off delay.

Look at Table 1. This table will convert a length error into a timer value to be inserted into a timer. Read down the left column for the speed you were moving. Then look across the top for the distance error in inches. From this distance, drop down to the line with your walk speed and read the delay time to be inserted.

For instance, suppose that your paint line came out to ten feet six inches (10'6") and you walked your machine at 2.1 MPH. Since the paint line should have been exactly ten feet, the error is $10'6" - 10' = 6"$. Look down the left column of TABLE 1 for 2.1 MPH, then look across the top row of the table for the distance error, which is six inches. Now look down the six inch column until you get to the row of numbers to the right of 2.1 MPH. The number at that intersection is 0.16 seconds.

Since the paint line was too long, you must enter a 0.16 second delay into the Paint-On Delay timer.

Use the pushbuttons to enter the “SETUP MACHINE” menu. If your line was too long, go to the “PAINT ON DELAY” screen, but if your line was too short, go to the “PAINT OFF DELAY” screen. Use the UP and DOWN buttons to set your timer value on the display. Then press NEXT to save the value in memory.

Check your new timer value by painting another three cycle pattern and measuring the paint length. It should be very close to 10 feet. If you want, you may try adjusting the timer up or down a little to “fine tune” the timer and get a more exact line length.

BEADS DELAY TIMER

The BEADS timer can be adjusted now to align the beads precisely with the paint. Because the CS11A controller includes a beads distance delay, the beads timing and alignment will be accurate at any speed.

The first thing to do is to get the beads line adjusted to ten feet long. Then we will align the paint and the beads lines. If you are using blow-off nozzles, turn them off for now.

Turn the BEADS switch ON and paint another 3 cycle pattern as before. This time, look at the second paint line and measure the length of the bead pattern. Don't worry about alignment with the paint line yet. If the bead line is over ten feet long, look up the error in Table 1 as you did for the paint line. Then set the time from the table into the BEADS ON DELAY timer. If the bead line is too short, set the time from the table into the BEADS OFF DELAY timer. Don't forget to press NEXT to save the values.

Now paint another set of lines as before and measure the distance between the point where the paint line starts and the point where the bead line starts. Look up the timer value needed in Table 1 where the speed row crosses the distance error column, just as you did before. Write this number down.

If the paint line starts first, we must delay the paint to align with the beads. By adding the same delay to both the Paint-On Delay timer and the Paint-Off Delay timer, the paint line length will not change, but the line will shift. To insert the delays, read the current value in the Paint-On Delay timer. Add the value from the table to the current timer value and change the timer to this new value. Go to the Paint-Off Delay timer, read the current value. Add the value you just got from the table to the current value of the Paint-Off Delay timer and enter the new value into this timer. Be sure to press NEXT or PREV after each new value is entered to save it.

If the bead line starts before the paint line, we must delay both the Beads-On and Beads-Off times to delay the bead line without changing its length. Read the current BEADS ON DELAY value, add the number you got from the table, and enter this new value into the timer. Repeat for the BEADS OFF DELAY. Be sure to press either PREV or NEXT after entering the values to save the new values.

This completes the setup and calibration of the CS11A Skipline Controller.

CONTROLS

This section will add some additional detail on the panel controls to the Front Panel section earlier in this manual.

The CS11A has four pushbuttons and three toggle switches (plus the POWER switch) on the panel. The pushbuttons are used mostly for setting up the controller, and the toggle switches are used for normal everyday operation.

The pushbuttons are used to select menu items and to change the values that are stored in the CS11A. You are probably already familiar with the pushbuttons from the Setup Procedure above.

The toggle switches will be used much more often than the pushbuttons. They are:

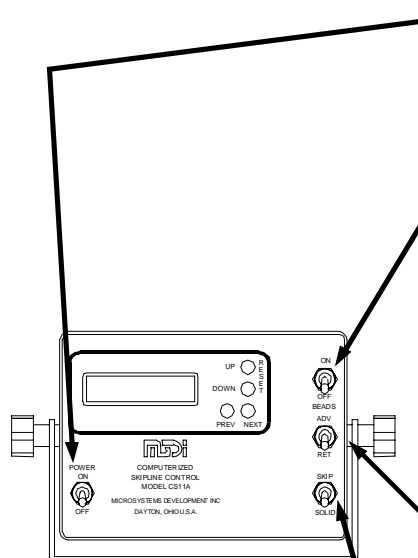

POWER

This switch turns the controller and solenoids on and off. The guns are locked off after power is first turned on to prevent unwanted painting. The lock is released by momentarily pushing the PAINT switch to either SKIP or SOLID.

BEADS

The BEADS switch turns the bead gun or dispenser on. The bead gun will be delayed according to the SETUP DELAYS menu to assure accurate alignment of the beads with the paint line. If the machine is not moving, however, the bead delays are disabled and the bead gun will work without delay. This is to allow for testing the bead gun without manually turning the sender wheel.

ADV/RET

This switch adjusts the skipline position to match a previously painted line. Pressing the switch to the ADV position moves the skipline farther out in front of you, while RET brings it in closer. If CYCLE-TRACK is turned on, the ADV and RET operation will also adjust the SKIP and CYCLE values stored in the controller. See CYCLE-TRACK below for more details.

PAINT

This switch is marked SKIP and SOLID. The switch has three positions. The Center position is OFF, no paint will be applied. The upper position is SKIP, and the paint gun will paint a skipping line according to the PAINT and CYCLE values. The lower position is SOLID and the paint gun will paint a continuous

line.

BASIC STRIPING

The CS11A is easy and intuitive to operate. Most users will have no trouble adapting the controller to the most challenging striping jobs.

As the CS11A is will usually be used mostly for temporary striping on highways, these instructions will concentrate on this application.

REPAINTING OLD LINES

The CS11A provides three features, FAST EDIT, CYCLE-TRACK and CYCLE-LOCK, that are especially useful for repainting old roadway lines.

USING FAST EDIT

The UP and DOWN pushbuttons change function when the CS11A is painting. Instead of adjusting the display contrast, they lengthen or shorten the CYCLE length by 0.1 foot per press. If the PAINT switch is set to OFF (Center) position, they again adjust contrast.

USING CYCLE-TRACK

The CYCLE-TRACK system will automatically adjust the length of the cycle to adjust the CS11A to old pre-painted lines. The cycle will shorten 0.1 feet whenever you operate the RETARD switch three times without operating the ADVANCE switch. Likewise, if you operate the ADVANCE switch, the cycle will be lengthened. Depending on how often you operate the ADVANCE or RETARD switch, these effects can take place over several cycles. This avoids 'hunting', or rapid changes in the cycle lengths that never hit the right length. With some practice, you will be able to judge exactly how many times to operate the switch to correct the line perfectly. Paint length is never changed.

To enable or disable CYCLE-TRACK, go to the SETUP MACHINE menu, select the CYCLE-TRACK submenu, and use UP or DOWN to turn it on or off. It will remain the way you set it until you change it.

USING CYCLE-LOCK

The CYCLE-LOCK feature allows your painting machine to

measure old skiplines 'on-the-fly' so you can repaint an old line without measuring it first.

To enable the CYCLE-LOCK system, go the SETUP MACHINE menu, select the CYCLE-LOCK submenu, and use UP or DOWN to turn it on. Unlike CYCLE-TRACK, CYCLE-LOCK turns itself off after each use.

The ADV/RET switch changes function when the CYCLE-LOCK is enabled. It is used to start and stop the measurements.

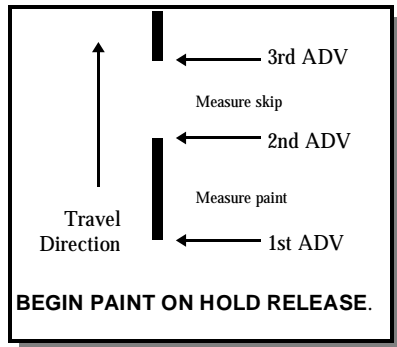

If you have chosen BEGIN PAINT ON HOLD RELEASE in the SETUP MACHINE menu, you will start your CYCLE-LOCK measurement at the beginning of a paint line. If you have chosen BEGIN SKIP ON HOLD RELEASE, you will start your CYCLE-LOCK measurement on a skip, at the end of a paint line.

To use CYCLE-LOCK, first enable it as described above. Roll the machine to the beginning of a paint line or the beginning of a skip depending on your set up described above.

If you want to paint the line as you measure it, turn the gun switch to SKIP position. If you want to measure only, leave the gun switch OFF (center position).

Press the ADVance switch to begin measuring and start rolling the machine along the line. The CS11A will measure the distance the machine moves.

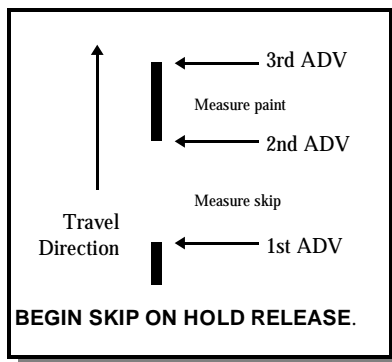

When you come to the end of the current paint line (or skip), press ADV again, and continue rolling the machine. When you come the end of the skip (or line) press ADV a third time. The display will now indicate the actual paint and cycle lengths that the machine measured, the CYCLE-LOCK system will turn itself off, and the ADV/RET switch will return to its normal function. If you are painting, you can continue to paint with the new cycle and paint lengths that you just measured. Of course, you can use the CYCLE-TRACK to make adjustments as necessary and the display will always show you the actual lengths of the paint line and the cycle.

The measurements made with the CYCLE-LOCK system replace the previous paint and cycle lengths stored in the CS11A and will remain until you change them, either manually through the SETUP SKIPLINE menu, or automatically by using CYCLE-LOCK again.

LAYOUT

The Layout System is useful in two common layout operations. In striping parking lots, the layout system allows you to mark the ends of the stall and aisle lines without taping. In highway work, the layout system allows for convenient pre-marking of the roadway center and edgelines.

SETTING UP THE LAYOUT SYSTEM

Before using the Layout System for parking lot painting, you must tell the CS11A the width of the stalls and the width of the aisles. First, press NEXT until you see "SETUP LAYOUT?" on the display. Press UP to begin the setup. The display will read "LAYOUT MODE" and the current ON/OFF condition. Press UP or DOWN to turn the layout mode on, then press NEXT. Now, use the UP and DOWN buttons to set the stall width to the desired value. This will be the actual width of the stall, regardless of walkway width. Then press NEXT to set the aisle width. The distance from one stall to the next will be the sum of the stall width and the aisle widths. If you don't want an aisle, set the aisle width to zero. Then press NEXT to set the "Pip" time for the paint marker. Some experimentation may be required to get the right pip time for your gun. Generally, you will want the pip time to be as short as possible while still making a recognizable spot on the pavement. The pips should be large enough to see from the other end of each stall line.

Generally, you will snap chalk lines to identify the ends of the stalls and walk the striper along these chalk lines to paint the stall marking pips. After marking the ends of the stalls, turn the layout mode off to resume normal striping. You can then paint the stalls.

The TAPE MEASURE function is provided for those cases where curbs or bumper stops prevent getting the machine into a good starting position and also to quickly lay out handicap accessible spaces. The TAPE MEASURE is automatically activated when the gun switch is placed in OFF position, and measures from the last 'pip' painted (NOT from when you put the switch in OFF position). The TAPE MEASURE may be reset to zero anytime it is displayed by pressing both UP and DOWN buttons simultaneously.

To explain the use of the TAPE MEASURE, suppose that you must paint a series of stalls that are curbed along the outer side of the first and last stall. The first stall is ADA Van Access, and the rest of the stalls are 9 feet wide. Set the LAYOUT MODE to ON, set STALL to 9.0 feet and set WALK to 0.0 feet (no aisles). Set the gun switch to OFF. Roll your machine along the end-of-stall chalk

line until the gun is lined up with the curb by the van accessible stall. Reset the TAPE MEASURE by pressing UP and DOWN buttons. Now, pull the machine backwards, watching the TAPE MEASURE display. When the display indicates 8.0 feet (the desired stall width for the van accessible stall), move the gun switch to SKIP and one paint pip will be painted and the TAPE MEASURE will reset. Turn gun switch back to OFF and the TAPE MEASURE will display the distance from the last paint pip. Again, watch the TAPE MEASURE for 8.0 feet for the access aisle. At the 8.0 foot count, again move the gun switch to SKIP and the next paint pip will be painted. Now, paint the pip marks for the rest of the stalls. To do this, set the gun switch to OFF and turn the machine around. Line up the marking gun with the last paint spot (on the van accessible aisle), turn the gun switch to SKIP. Now walk the machine (forward) along the chalk line. The automatic LAYOUT system will then begin painting the marks at every nine feet to lay out the remaining spaces.

SETTING UP THE LAYOUT FOR REMARKING

To use the CS11A for remarking, set the AISLE to zero and set the STALL width to the desired remark pip spacing. Note that the distances that you set up for remarking will not change the regular SKIP and CYCLE distances that are available when LAYOUT is turned off.

BATTERY MAINTENANCE **6**

The battery supplied with your CS11A is a sealed gelled electrolyte lead-acid battery, also known as a “Gel-Cell”. It is known for its ruggedness and long life. However, the battery can be damaged by misuse. For the best performance, be sure to follow these rules:

1. Do not let the battery run completely down. When the “flashing star” in the lower right corner of the CS11A display changes to a “flashing B”, the battery is nearing the end of its charge. Recharge as soon as possible.
2. Do not use an automotive charger to recharge the battery. Use only a charger specifically designed to recharge gelled electrolyte batteries.
3. Do not use the battery for engine starting. It is not designed for heavy current draw.
4. For longest life, store the battery indoors if you have a cold off-season when the CS22 system is not used. Occasionally recharge the battery during the off-season to maintain the charge.
5. In an emergency, you can substitute a 12 volt dry cell lantern battery for the gel cell. Be sure to observe polarity when installing the new battery. Do not attempt to recharge a dry cell battery.

IF YOU HAVE AN ELECTRIC START STRIPER

If you are running the CS11A Controller from the electrical system on your striper, observe the following warnings:

1. Be sure to turn the CS11A Controller OFF before connecting a battery charger to your battery. The protective circuits in the CS11A will usually prevent damage to the controller, but will cause the controller fuse to blow.
2. It is good practice to turn the CS11A OFF when starting the engine. The drop in voltage during cranking may incorrectly trip the low battery indicator in the CS11A.

BUILT-IN TEST PROGRAM **7**

The CS11A has a built-in test program to check the front panel switches for proper operation and to allow resetting the stored time and distance data to the factory default values. To start this program, hold down both the UP and DOWN buttons and switch on the POWER switch. Alternatively, you may press both the PREV and NEXT buttons to start the diagnostics. After the sign-on message appears, you can release the buttons. The display will ask "RESET DEFAULTS?" Press DOWN for NO unless you wish to reset all of the calibration and delay values to factory default values. After pressing DOWN, the display will say "SWITCH PANEL DIAGNOSTIC". The display will show three letter abbreviations for each switch on the panel that is turned on. You may test all of the switches to assure that they are working properly. When you are finished, turn the power off, then on again to restore normal operation.

If the diagnostics routine does not start as above when you switch on the power, try using the PREV and NEXT buttons. It could be that either the UP or the DOWN button is bad.

TROUBLESHOOTING **8**

The following hints may help if you are having trouble with your system:

No data on display	Is battery connected? Is the polarity correct? Is battery charged? Check or replace the fuse.
Gun reads Open Circuit	Is the solenoid connected? Check solenoid for continuity. If solenoid is OK, check cable for cuts or abrasions.
Gun reads Short Circuit	Check solenoid for internal short. If OK, check cable for cuts or abrasions. Some intermittent duty solenoids draw enough current to trip the overload circuitry in the CS11A. Use only recommended solenoids.
Solids paint, Skips don't	Look for the blinking star in the lower right corner of the display. If it isn't blinking, check the sender to make sure that it is turning. Check sender wiring. Try another sender if possible.

MODEL CS11A TIMER SETTING TABLE

		-----LENGTH ERROR INCHES-----									
		1	2	3	4	5	6	7	8	9	10
SPEED											
	1.0	0.056	0.114	0.170	0.228	0.284	0.340	0.398	0.454	-	-
	1.2	0.048	0.094	0.142	0.190	0.236	0.284	0.332	0.378	0.426	0.474
	1.4	0.040	0.082	0.122	0.162	0.202	0.244	0.284	0.324	0.366	0.406
	1.6	0.036	0.072	0.106	0.142	0.178	0.214	0.248	0.284	0.320	0.356
	1.8	0.032	0.064	0.094	0.126	0.158	0.190	0.220	0.252	0.284	0.316
	2.0	0.028	0.056	0.086	0.114	0.142	0.170	0.198	0.228	0.256	0.284
M	2.2	0.026	0.052	0.078	0.104	0.130	0.154	0.180	0.206	0.232	0.258
	2.4	0.024	0.048	0.072	0.094	0.118	0.142	0.166	0.190	0.214	0.236
I	2.6	0.022	0.044	0.066	0.088	0.110	0.132	0.152	0.174	0.196	0.218
	2.8	0.020	0.040	0.060	0.082	0.102	0.122	0.142	0.162	0.182	0.202
L											
	3.0	0.018	0.038	0.056	0.076	0.094	0.114	0.132	0.152	0.170	0.190
E	3.2	0.018	0.036	0.054	0.072	0.088	0.106	0.124	0.142	0.160	0.178
	3.4	0.016	0.034	0.050	0.066	0.084	0.100	0.116	0.134	0.150	0.168
S	3.6	0.016	0.032	0.048	0.064	0.078	0.094	0.110	0.126	0.142	0.158
	3.8	0.014	0.030	0.044	0.060	0.074	0.090	0.104	0.120	0.134	0.150
	4.0	0.014	0.028	0.042	0.056	0.072	0.086	0.100	0.114	0.128	0.142
	4.2	0.014	0.028	0.040	0.054	0.068	0.082	0.094	0.108	0.122	0.136
P	4.4	0.012	0.026	0.038	0.052	0.064	0.078	0.090	0.104	0.116	0.130
	4.6	0.012	0.024	0.038	0.050	0.062	0.074	0.086	0.098	0.112	0.124
E	4.8	0.012	0.024	0.036	0.048	0.060	0.072	0.082	0.094	0.106	0.118
R	5.0	0.012	0.022	0.034	0.046	0.056	0.068	0.080	0.090	0.102	0.114
	5.2	0.010	0.022	0.032	0.044	0.054	0.066	0.076	0.088	0.098	0.110
	5.4	0.010	0.022	0.032	0.042	0.052	0.064	0.074	0.084	0.094	0.106
	5.6	0.010	0.020	0.030	0.040	0.050	0.060	0.072	0.082	0.092	0.102
	5.8	0.010	0.020	0.030	0.040	0.048	0.058	0.068	0.078	0.088	0.098
H	6.0	0.010	0.018	0.028	0.038	0.048	0.056	0.066	0.076	0.086	0.094
	6.2	0.010	0.018	0.028	0.036	0.046	0.054	0.064	0.074	0.082	0.092
O	6.4	0.008	0.018	0.026	0.036	0.044	0.054	0.062	0.072	0.080	0.088
	6.6	0.008	0.018	0.026	0.034	0.044	0.052	0.060	0.068	0.078	0.086
U	6.8	0.008	0.016	0.026	0.034	0.042	0.050	0.058	0.066	0.076	0.084
R	7.0	0.008	0.016	0.024	0.032	0.040	0.048	0.056	0.064	0.074	0.082
	7.2	0.008	0.016	0.024	0.032	0.040	0.048	0.056	0.064	0.072	0.078
	7.4	0.008	0.016	0.024	0.030	0.038	0.046	0.054	0.062	0.070	0.076
	7.6	0.008	0.014	0.022	0.030	0.038	0.044	0.052	0.060	0.068	0.074
	7.8	0.008	0.014	0.022	0.030	0.036	0.044	0.050	0.058	0.066	0.072
	8.0	0.008	0.014	0.022	0.028	0.036	0.042	0.050	0.056	0.064	0.072
	8.2	0.006	0.014	0.020	0.028	0.034	0.042	0.048	0.056	0.062	0.070
	8.4	0.006	0.014	0.020	0.028	0.034	0.040	0.048	0.054	0.060	0.068
	8.6	0.006	0.014	0.020	0.026	0.034	0.040	0.046	0.052	0.060	0.066
	8.8	0.006	0.012	0.020	0.026	0.032	0.038	0.046	0.052	0.058	0.064
	9.0	0.006	0.012	0.018	0.026	0.032	0.038	0.044	0.050	0.056	0.064
	9.2	0.006	0.012	0.018	0.024	0.030	0.038	0.044	0.050	0.056	0.062
	9.4	0.006	0.012	0.018	0.024	0.030	0.036	0.042	0.048	0.054	0.060
	9.6	0.006	0.012	0.018	0.024	0.030	0.036	0.042	0.048	0.054	0.060
	9.8	0.006	0.012	0.018	0.024	0.028	0.034	0.040	0.046	0.052	0.058
	10.0	0.006	0.012	0.018	0.022	0.028	0.034	0.040	0.046	0.052	0.056
	10.2	0.006	0.012	0.016	0.022	0.028	0.034	0.038	0.044	0.050	0.056
	10.4	0.006	0.010	0.016	0.022	0.028	0.032	0.038	0.044	0.050	0.054
	10.6	0.006	0.010	0.016	0.022	0.026	0.032	0.038	0.042	0.048	0.054
	10.8	0.006	0.010	0.016	0.022	0.026	0.032	0.036	0.042	0.048	0.052

MODEL CS11A TIMER SETTING TABLE

		-----LENGTH ERROR CENTIMETERS-----										
		2	4	6	8	10	12	14	16	18	20	
SPEED	1.0	0.072	0.144	0.216	0.288	0.360	0.432	-	-	-	-	
	1.2	0.060	0.120	0.180	0.240	0.300	0.360	0.420	0.480	-	-	
	1.4	0.052	0.102	0.154	0.206	0.258	0.308	0.360	0.412	0.462	-	
	1.6	0.046	0.090	0.136	0.180	0.226	0.270	0.316	0.360	0.406	0.450	
	1.8	0.040	0.080	0.120	0.160	0.200	0.240	0.280	0.320	0.360	0.400	
	2.0	0.036	0.072	0.108	0.144	0.180	0.216	0.252	0.288	0.324	0.360	
	K	2.2	0.032	0.066	0.098	0.130	0.164	0.196	0.230	0.262	0.294	0.328
		2.4	0.030	0.060	0.090	0.120	0.150	0.180	0.210	0.240	0.270	0.300
	I	2.6	0.028	0.056	0.084	0.110	0.138	0.166	0.194	0.222	0.250	0.276
		2.8	0.026	0.052	0.078	0.102	0.128	0.154	0.180	0.206	0.232	0.258
L	3.0	0.024	0.048	0.072	0.096	0.120	0.144	0.168	0.192	0.216	0.240	
O	3.2	0.022	0.046	0.068	0.090	0.112	0.136	0.158	0.180	0.202	0.226	
	3.4	0.022	0.042	0.064	0.084	0.106	0.128	0.148	0.170	0.190	0.212	
M	3.6	0.020	0.040	0.060	0.080	0.100	0.120	0.140	0.160	0.180	0.200	
	3.8	0.018	0.038	0.056	0.076	0.094	0.114	0.132	0.152	0.170	0.190	
E	4.0	0.018	0.036	0.054	0.072	0.090	0.108	0.126	0.144	0.162	0.180	
	4.2	0.018	0.034	0.052	0.068	0.086	0.102	0.120	0.138	0.154	0.172	
T	4.4	0.016	0.032	0.050	0.066	0.082	0.098	0.114	0.130	0.148	0.164	
	4.6	0.016	0.032	0.046	0.062	0.078	0.094	0.110	0.126	0.140	0.156	
E	4.8	0.016	0.030	0.046	0.060	0.076	0.090	0.106	0.120	0.136	0.150	
R	5.0	0.014	0.028	0.044	0.058	0.072	0.086	0.100	0.116	0.130	0.144	
	5.2	0.014	0.028	0.042	0.056	0.070	0.084	0.096	0.110	0.124	0.138	
S	5.4	0.014	0.026	0.040	0.054	0.066	0.080	0.094	0.106	0.120	0.134	
	5.6	0.012	0.026	0.038	0.052	0.064	0.078	0.090	0.102	0.116	0.128	
	5.8	0.012	0.024	0.038	0.050	0.062	0.074	0.086	0.100	0.112	0.124	
	6.0	0.012	0.024	0.036	0.048	0.060	0.072	0.084	0.096	0.108	0.120	
	6.2	0.012	0.024	0.034	0.046	0.058	0.070	0.082	0.092	0.104	0.116	
P	6.4	0.012	0.022	0.034	0.046	0.056	0.068	0.078	0.090	0.102	0.112	
	6.6	0.010	0.022	0.032	0.044	0.054	0.066	0.076	0.088	0.098	0.110	
E	6.8	0.010	0.022	0.032	0.042	0.052	0.064	0.074	0.084	0.096	0.106	
R	7.0	0.010	0.020	0.030	0.042	0.052	0.062	0.072	0.082	0.092	0.102	
	7.2	0.010	0.020	0.030	0.040	0.050	0.060	0.070	0.080	0.090	0.100	
	7.4	0.010	0.020	0.030	0.038	0.048	0.058	0.068	0.078	0.088	0.098	
	7.6	0.010	0.018	0.028	0.038	0.048	0.056	0.066	0.076	0.086	0.094	
	7.8	0.010	0.018	0.028	0.036	0.046	0.056	0.064	0.074	0.084	0.092	
H	8.0	0.010	0.018	0.028	0.036	0.046	0.054	0.064	0.072	0.082	0.090	
	8.2	0.008	0.018	0.026	0.036	0.044	0.052	0.062	0.070	0.080	0.088	
O	8.4	0.008	0.018	0.026	0.034	0.042	0.052	0.060	0.068	0.078	0.086	
	8.6	0.008	0.016	0.026	0.034	0.042	0.050	0.058	0.066	0.076	0.084	
U	8.8	0.008	0.016	0.024	0.032	0.040	0.050	0.058	0.066	0.074	0.082	
	9.0	0.008	0.016	0.024	0.032	0.040	0.048	0.056	0.064	0.072	0.080	
R	9.2	0.008	0.016	0.024	0.032	0.040	0.046	0.054	0.062	0.070	0.078	
	9.4	0.008	0.016	0.022	0.030	0.038	0.046	0.054	0.062	0.068	0.076	
	9.6	0.008	0.016	0.022	0.030	0.038	0.046	0.052	0.060	0.068	0.076	
	9.8	0.008	0.014	0.022	0.030	0.036	0.044	0.052	0.058	0.066	0.074	
	10.0	0.008	0.014	0.022	0.028	0.036	0.044	0.050	0.058	0.064	0.072	
	10.2	0.008	0.014	0.022	0.028	0.036	0.042	0.050	0.056	0.064	0.070	
	10.4	0.006	0.014	0.020	0.028	0.034	0.042	0.048	0.056	0.062	0.070	
	10.6	0.006	0.014	0.020	0.028	0.034	0.040	0.048	0.054	0.062	0.068	
	10.8	0.006	0.014	0.020	0.026	0.034	0.040	0.046	0.054	0.060	0.066	

CS11A BASE MENU

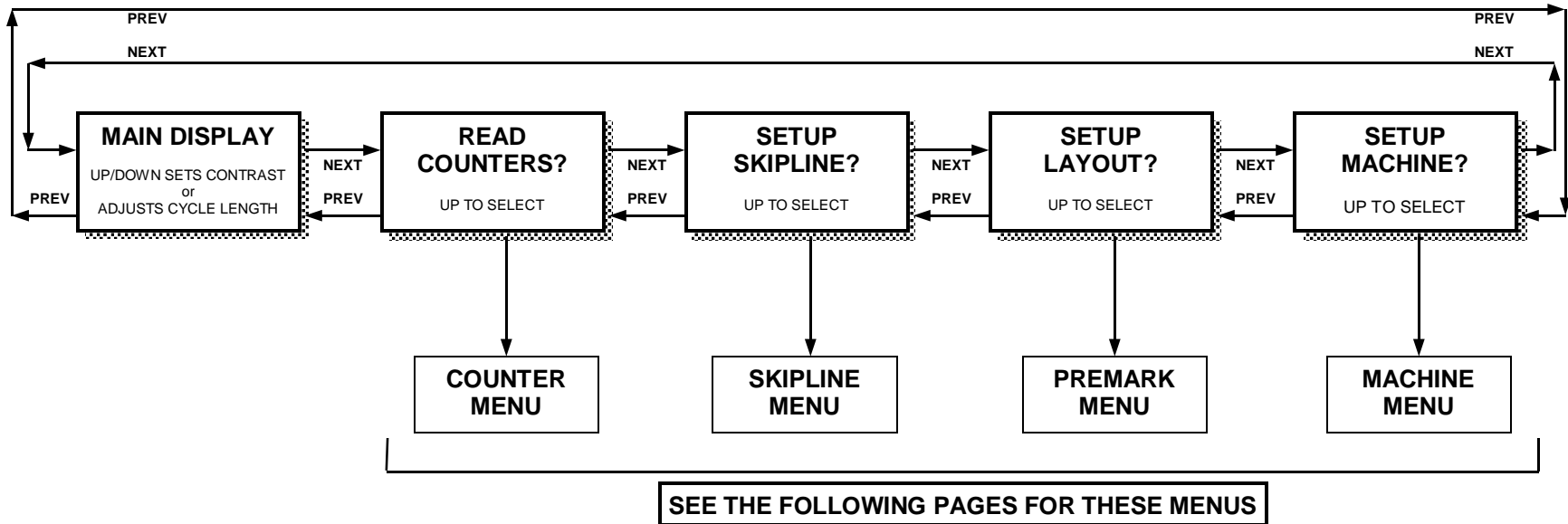

CS11A FOOTAGE COUNTERS

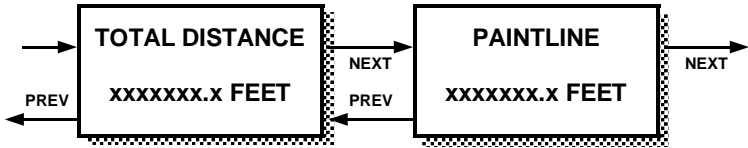

**PRESSING BOTH THE UP AND
THE DOWN BUTTONS
SIMULTANEOUSLY WILL
RESET THE DISPLAYED
COUNTER.**

CS11A SETUP SKIPLINE MENU

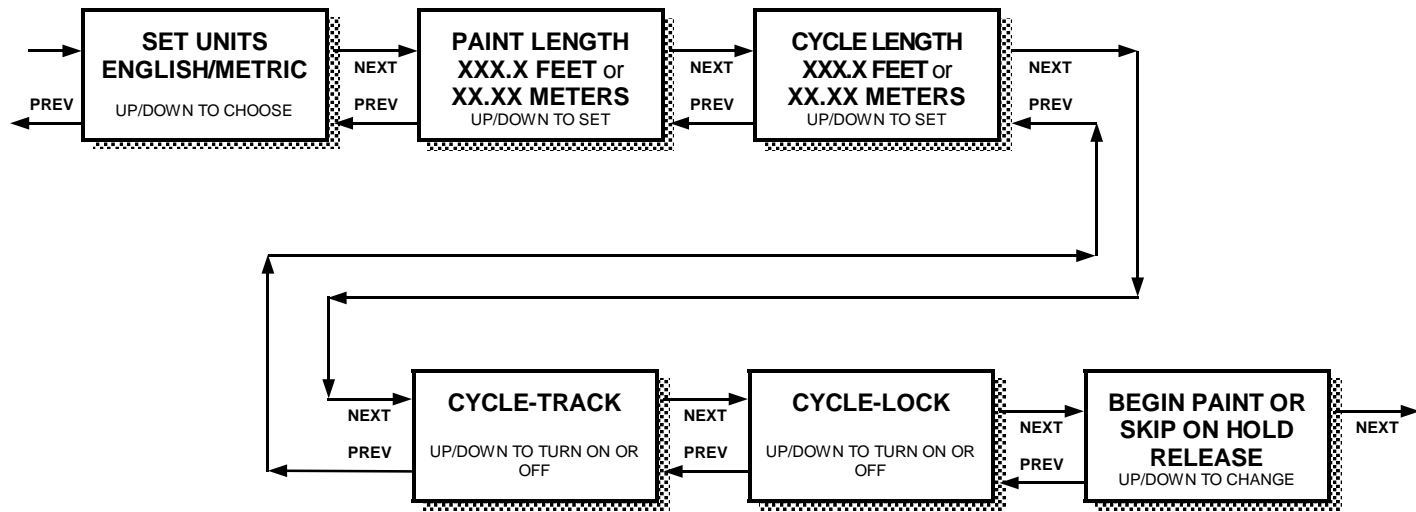

CS11A LAYOUT MENU

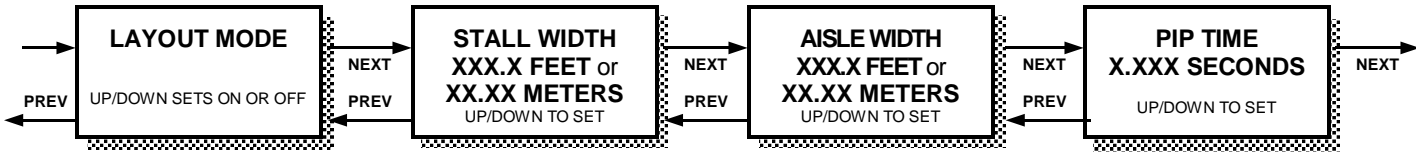

CS11A MACHINE SETUP MENU

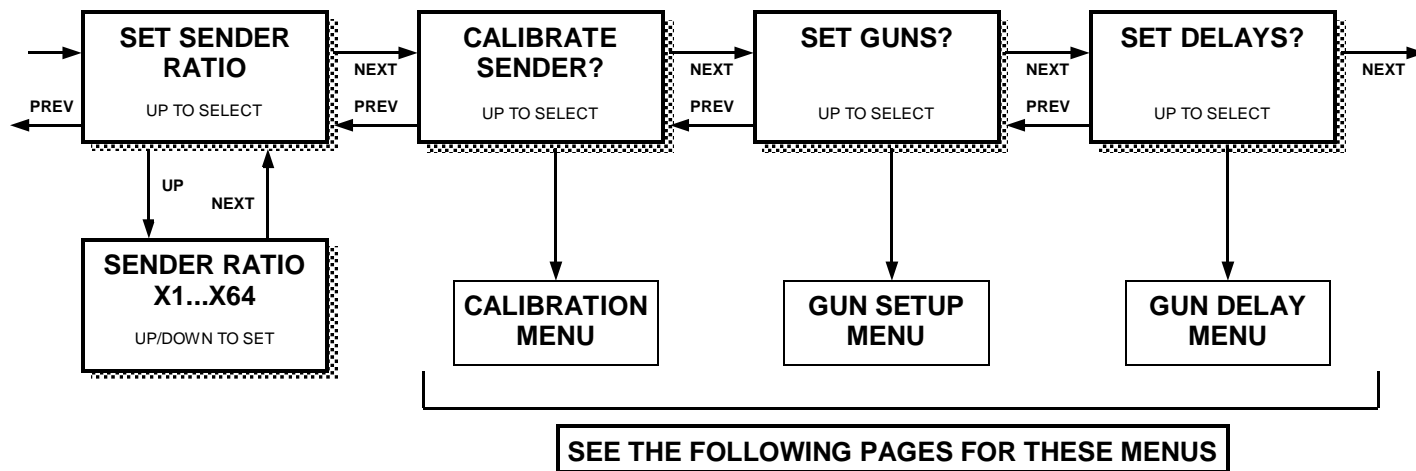

CS11A CALIBRATION MENU

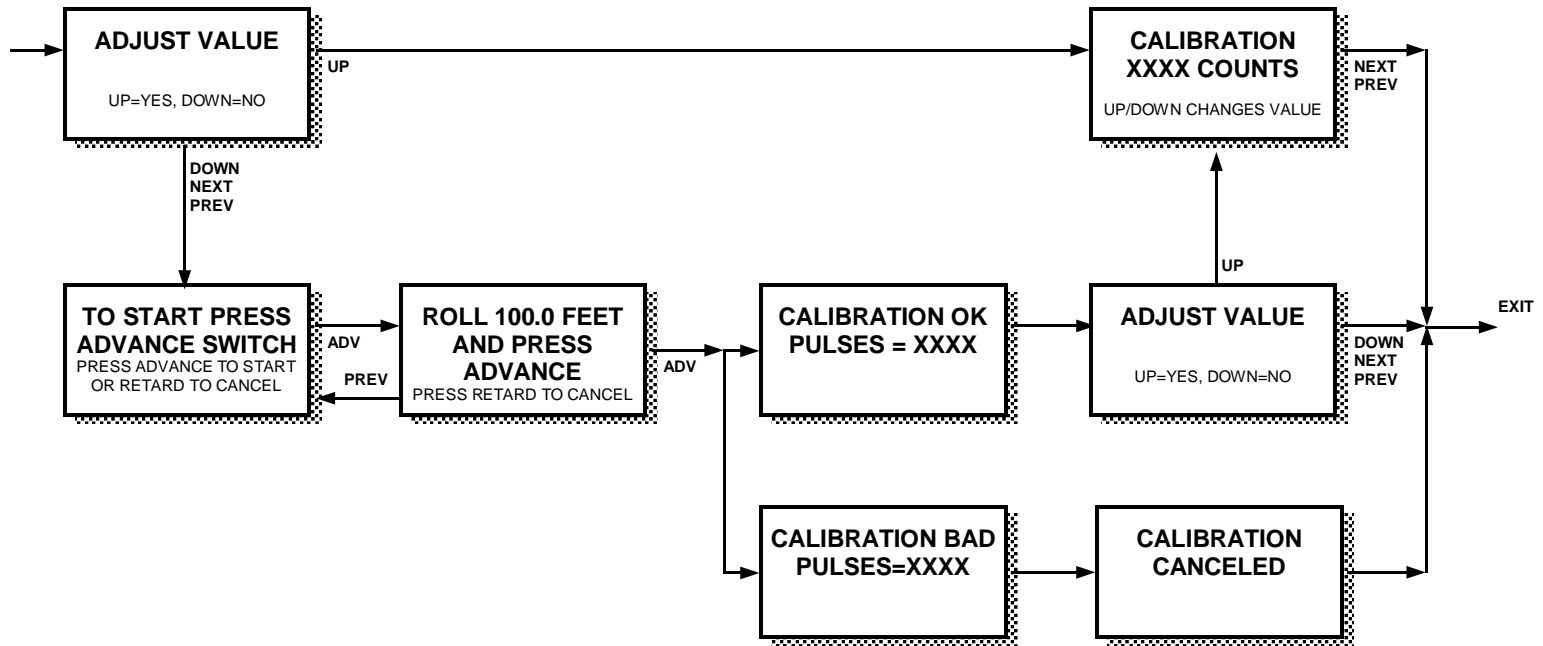

CS11A GUN SETUP MENU



CS11A SET DELAYS MENU



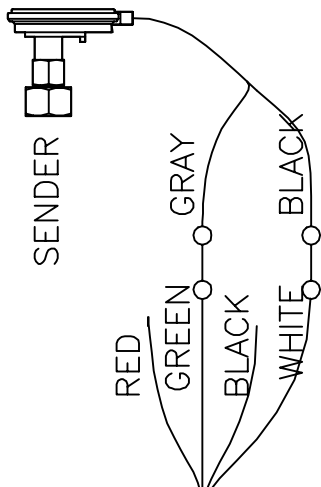
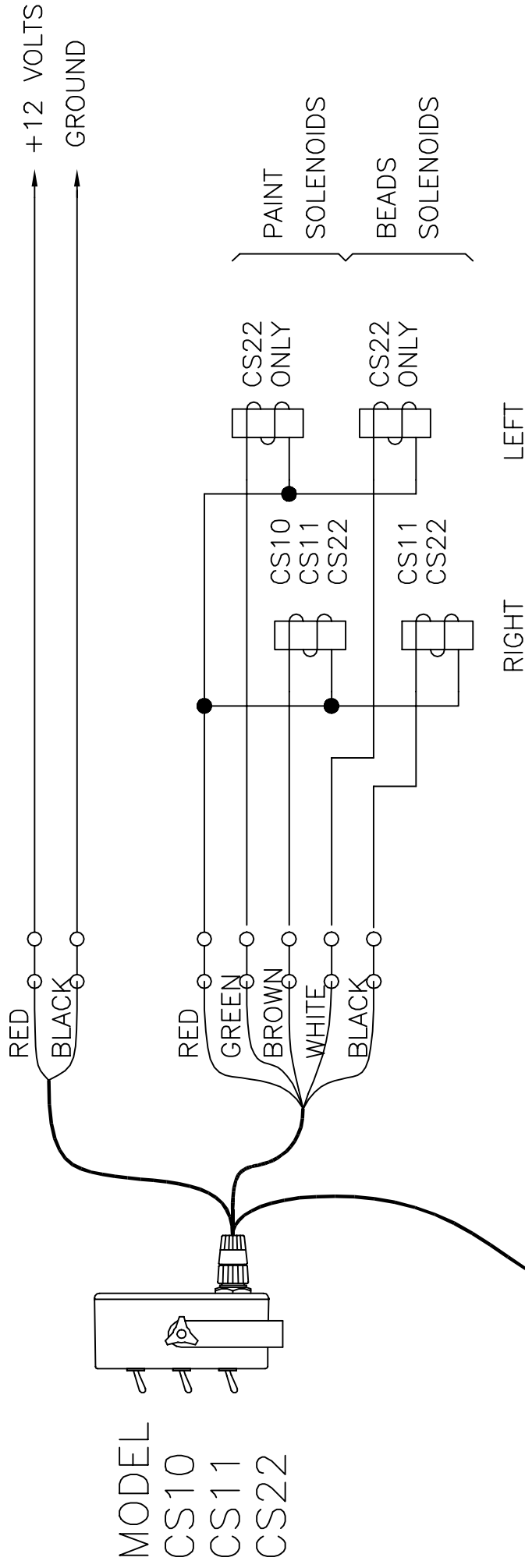

4/27/93

Rev 9/28/95

INSTALLATION DIAGRAM FOR MODEL CS SERIES SKIPLINE CONTROLLERS