

INSTRUCTION MANUAL  
FOR THE  
MODEL R10B  
REFLECTOR SKIP SYSTEM

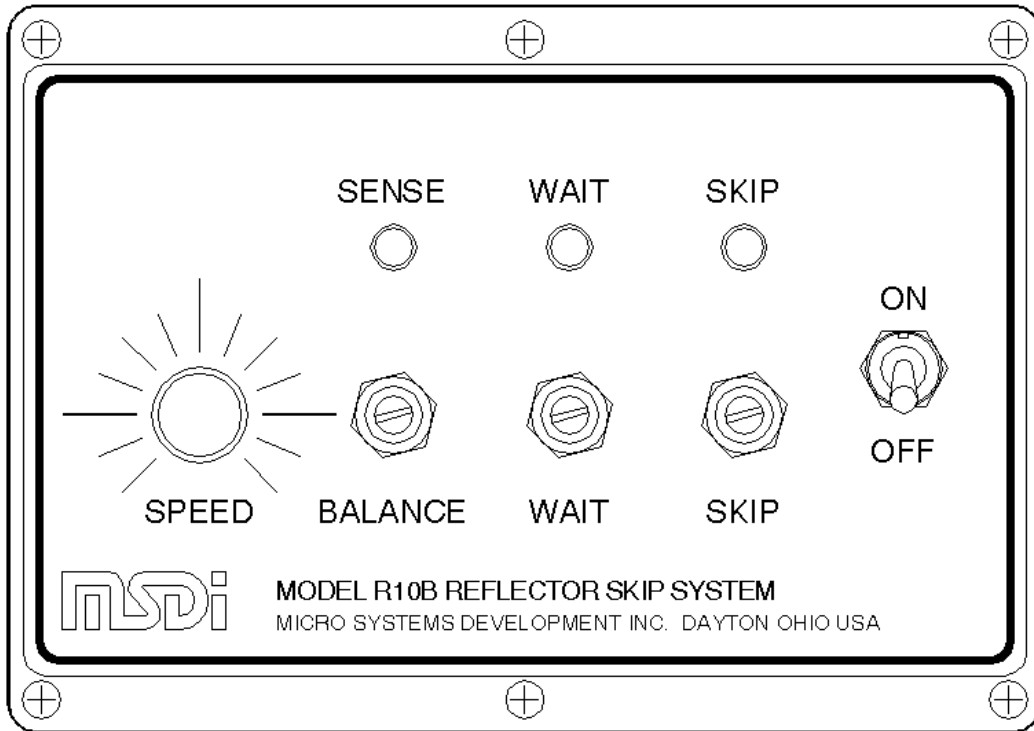

MICRO SYSTEMS DEVELOPMENT, INC.  
46 MARCO LANE  
DAYTON, OHIO 45458  
937-438-3567  
[www.msdicontrols.com](http://www.msdicontrols.com)

INSTALLATION INSTRUCTIONS  
for the  
MODEL R10 REFLECTOR SKIP SYSTEM

**APPLICATION**

The Model R10B Reflector Skip System is intended to be used with roadway lane marking equipment, where it detects the presence of snowplowable lane marking reflectors and automatically interrupts the paint guns so as to prevent overpainting the reflectors. The system is based on a precision magnetic balance principle, and is designed to be particularly sensitive when detecting cast iron reflector blocks. It is relatively insensitive to rebars and remesh in the pavement, and ignores foil-backed temporary lane marking tape and survey spikes.

The R10B System is designed to be used with a wide variety of Skipline Controllers (Skip Timers), including those that control both the high and low side of the solenoid valves. It will control up to four paint guns simultaneously. It is not necessary to skip bead guns.

The R10B System is intended to be used on a 12 volt electrical system with negative ground. Do not attempt to connect it to a 24 volt system.

**EQUIPMENT SUPPLIED**

The Model R10B System is made up of a SENSOR HEAD, a CONTROL BOX and an interconnecting CABLE. The Sensor Head is mounted in front of the paint guns on the gun carriage, the Control Box is mounted in the vicinity of the skipline controller (skip timer) and the Cable joins the two. The Control Box is wired into the paint gun solenoid circuits where it can override the skipline controller outputs.

**SENSOR HEAD INSTALLATION**

The Sensor Head is a magnetic device that senses the magnetic field produced by the cast iron in the reflector mounting block. It is mounted in front of the paint guns on the gun carriage so that it can sense the presence of a reflector and cause a momentary interruption in the paint line as the guns pass over the reflector.

**HEAD MOUNTING LOCATION**

The Sensor Head will detect a reflector block that passes under it from front to

rear. Reflectors that pass near the ends of the Head may be sensed also, but the sensitivity falls off rapidly beyond the ends of the Head. Therefore, the Head should be suspended on the centerline of the paint guns so that any reflector in danger of being painted will pass beneath the Sensor Head.

The Sensor Head has been carefully designed to have a shallow sensitivity field so that it will ignore rebars and mesh in the pavement. For this reason, the height of the Head above the roadway is somewhat critical. The optimum clearance between the bottom of the Head and the roadway is 3 inches, but 2 to 4 inches will work. Some or all of the reflectors will be missed if the clearance exceeds 5 inches. Clearances below 2 inches are not recommended as the Head may strike the roadway and it becomes more difficult to protect the Head from stones thrown by the vehicle tires or contact with curbs.

## MOUNTING HINTS

In applications where the paint gun carriage follows the rear vehicle tires, be sure to provide a mud flap or stone shield to prevent rocks thrown by the tires from striking the Sensor Head. The Sensor is very rugged, but it is NOT indestructible!

The 18 inch Sensor Head weighs 14 pounds and the 12 Head weighs 11 pounds. Be sure to provide enough strength in the mounting to support this weight. If the Sensor is mounted in front of the dolly wheel, as in the Version A sketches, we recommend 2" angle or channel iron for the supports. For cases where there is room to mount the Head behind the dolly wheel, 1" angle iron is generally strong enough (see Version B sketches).

**NEVER WELD OR BRAZE DIRECTLY TO THE SENSOR HEAD!** The heat and magnetic fields associated with welding can damage the Head. When installing the mounting brackets, remove the Head from the work area to prevent sparks and drill chips from falling into the connector. Leave the connector covered until you are ready to attach the cable.

In the case where the Head is mounted in front of the dolly wheel, be sure to allow room for the wheel to swing around freely when backing up.

Blow-off nozzles mounted near the Sensor will not disturb its operation. They may be mounted in front of, beside or behind the Sensor. Once the nozzles are in place and the system is calibrated, the nozzles must not be moved. If they are moved, the Sensor calibration may change, resulting in improper operation. In this case, resetting the sensitivity will be required.

## FINAL INSTALLATION

After all welding and drilling work is complete, mount the Head with four 1/2"

diameter bolts. Be sure that the Sensor Head is mounted with its connector toward the rear of the vehicle. If the Sensor is mounted backwards, it will not work correctly.

## **CONTROL BOX INSTALLATION**

### **MOUNTING**

The Control Box should be installed near the gun operator. There is a Speed compensating adjustment on the front of the box that may need adjustment from time to time, so it is desirable to make this adjustment convenient for the skipline operator.

### **WIRING**

The first step in wiring the system is to determine the type of skipline controller that you have on your machine. When we talk about "high side" with reference to solenoid valves, we are talking about the wire that connects to 12 volts, either directly or through the skipline controller, and when we talk about "low side" we are talking about the solenoid wire that connects to ground, again either directly or through the skipline controller.

The R10B uses transistors in the output circuits and will work only when installed on the "high side" or positive side of the solenoid circuit. If you don't have a wiring diagram available for your skipline control system, you will have to determine which side of each solenoid is the "high side" by using a multi-meter (or V-O-M) or a test light

There are three common types of controllers that will work with the R10B System:

1. High Drive- Here the skipline controller switches 12 volts to the high side wire of the solenoid valves, and the low side of each valve coil is permanently grounded. In this system, the skipline controller supplies all power to operate the valves. Note that terminal 1 on the R10B Controller terminal block controls terminal 1 on the R10B Solenoid terminal block, and so on for the other three terminals on each block. You will need to break the wire going to each solenoid high side. You will then connect the end of the wire from the controller to one of the R10B Controller Block terminals, and the end of the wire from the solenoid will connect the R10B Solenoid Block terminal with the same number. Most LDI controls are of this type.
2. Low Drive- Here the skipline controller switches the low side of each valve coil to ground. The high sides of the coils are connected through the master switch to 12 volts. In this system, the master switch supplies power to operate the valves and the skipline controller only controls the flow of current through the valve coils by connecting them to ground or disconnecting them. Because there is no high side drive from the skipline controller, you must connect a jumper wire to

the four R10B Controller Block terminals. Examples of this type of skipline controller are the Kelly-Creswell Mark 40C and all MSDI Skipline Controllers.

3. Both Drive- Here the skipline controller switches both the low side and the high side of the valve coil. Both wires from each solenoid valve are connected to the skipline controller. Examples of this type of controller are the Kelly-Creswell Mark 40A and Mark 40B.

Refer to the wiring diagram for your vehicle, or trace out the wiring to determine which type of skipline controller you have. Then refer to the appropriate wiring chart in this manual to make the proper connections to the R10B Control Unit. Note that the diagrams sometimes include wiring color codes. These codes may or may not apply to your system.

In every case the R10B Reflector Skip System acts like a High Drive controller. You will not have to disconnect any of the low side solenoid wires to install this system. All of the installation wiring will be done on the high side wires.

If your system uses fewer than four guns, simply leave the unused terminals in the R10B Control box unconnected.

Connect positive 12 volts to the power terminal (marked +12) in the R10B Control box. The 12 volts to the Control Box **MUST** be supplied through the master power switch on your control panel. Connect a ground to the ground terminal in the R10B (marked GND). Both the R10B and the skipline controller must be connected to a common ground. **Be very careful not to reverse the power connections to the R10B Control Unit. Doing so will either blow your master fuse or will damage the R10B circuit card.**

The R10B Control Box includes a 5 ampere fuse to protect its internal circuitry. Do not install a heavier fuse.

## CABLE INSTALLATION

After the Sensor Head and the Control Box are mounted, the Cable can be installed between the Control Box to the Sensor Head. Note that the cable has one female connector and one male connector. The female connector attaches to the Head, and the male end attaches to the Control Unit.

When installing the cable, be sure to allow enough slack so that the cable will not be stretched when the paint carriage is raised or lowered, or when the carriage is extended out from the side of the vehicle.

Support the cable by tying it to other hoses or cable so that it will not drag on the ground or get caught in moving parts.

The connector on the Sensor Head has a small amount of silicone grease installed to prevent moisture from shorting the connections. If the grease needs to be renewed it can be purchased in any auto supply store as "dielectric tune-up grease."

## **CALIBRATION**

### **OVERVIEW**

Calibration of the R10B Reflector Detector is quite easy, but must be carefully done to ensure the best performance.

The calibration is performed in three steps, the first is setting sensitivity, the second is setting the wait delay and the third is setting the skip time delay.

The second and third steps will require driving the vehicle on a highway with reflectors at your normal operating speed. If possible, use water or something other than paint in the paint tank during these two steps to avoid painting over reflectors while you are calibrating.

### **SENSITIVITY (also called BALANCE)**

To set the sensitivity, move your truck into the parking lot or driveway, away from the rebars and remesh in the garage floor.

Remove the cover from the electronics unit by removing six screws.

Apply power to the R10B system. Be sure that none of the cover wiring is shorted to the cabinet.

Move the carriage into the normal painting position. Manually position the dolly wheel into the normal operating position.

Adjust the BALANCE control on the front panel to mid-position.

Watch the SENSE lamp on the front panel as you adjust the SENS control on the circuit card inside the R10B Electronics Cabinet. Turn the control clockwise until the SENSE lamp just turns on, then counterclockwise until the lamp just turns off.

This completes the sensitivity adjustment. Fine adjustments can be made later when painting using the BALANCE control.

Replace the cover, using six screws.

## SETTING WAIT DELAY

This step will fine tune the Sensor settings made in Step 1 and then set the first delay, called the WAIT delay.

Take the vehicle out on a road with reflectors. You may want to paint with water for this procedure. Drive slowly with the paint carriage and Sensor Head over the line of reflectors. Don't turn any paint on yet. With the paint carriage in normal operating position, observe the SENSE lamp. It should come on as the Sensor Head approaches a reflector, and should turn off when the Sensor Head is exactly centered over the reflector. **IMPORTANT:** The lamp **MUST STAY OFF** between reflectors. If the SENSE lamp remains on between reflectors, adjust the BALANCE control on the circuit card **VERY SLIGHTLY** counterclockwise until the lamp stays off between reflectors. Turning this control too far counterclockwise can cause the system to miss reflectors.

Accelerate to normal operating speed. Turn the R10B Control Switch on, then turn the paint system on and set it for solid lines. Adjust the WAIT control so that the paint stops at the desired point behind the reflector.

## SETTING SKIP DELAY

Be sure that the vehicle is moving at the normal operating speed. Adjust the SKIP control until the skip length is correct and the paint begins again at the desired point in front of the reflector.

ALL DONE! The R10B system is now calibrated.

## RE-CALIBRATION

The R10B System is extremely stable and seldom requires recalibration. Recalibration will be required if the position of the Sensor Head is changed, or if changes are made in the configuration of any iron or steel parts in or around the gun carriage. Recalibration will also be required if any of the R10B System parts are replaced.

The need for recalibration will be evident if the system misses reflectors or the system senses reflectors that aren't there and the BALANCE control does not have sufficient range to correct the problem.

Extremely heavy concentrations of structural steel in the roadway, such as overpass and bridge expansion joints, will be sensed and skipped. If it is important that you not skip these joints, move the ON-OFF switch to OFF position just prior to reaching the joint. This will disable the skip, but the panel lights will still operate.

## **OPERATION**

### **CONTROLS and INDICATORS**

The front panel of the R10B Control Box is equipped with three LED (Light emitting diode) lamps. These lamps indicate the status of the control system at all times.

The leftmost lamp is the SENSE lamp. This lamp, when on, indicates that the Sensor Head is approaching a reflector. The SENSE lamp will turn off at the exact instant that the Head is centered over a reflector. The WAIT delay will begin at this instant.

The center lamp is the WAIT lamp. This lamp indicates that a reflector has been sensed, and is currently moving toward the paint gun.

The rightmost lamp is the SKIP lamp. This lamp indicates that the paint guns are shut off while skipping over a reflector.

The front panel also has four adjustable controls and one toggle switch.

The toggle switch allows the R10B system to be bypassed. When the switch is in the OFF position, the R10B has no effect and paint lines will not be interrupted. The R10B Panel Lamps will continue to work, even when the switch is off. The bypass function is useful for situations where unusual concentrations of iron or steel are found in the roadway, leading to erratic paint line interruptions. An example would be the steel deck of a bridge or overpass, where the heavy steel girders beneath the roadway may occasionally confuse the R10B System. It is also good practice to turn the switch off when painting roadways without reflectors. Note that this switch does NOT control the power to the R10B.

The SPEED control is a fine adjustment on the WAIT delay. It compensates for variations in vehicle speed by allowing the operator to make a small adjustment in the position of the paint skip.

If the truck slows down, the gap in the paint will move forward, toward the Sensor Head. With only a small reduction in speed, the gap will move far enough forward that the reflector will get painted. By adjusting the SPEED knob counterclockwise, the wait delay will be increased enough to keep the gap centered on the reflector. Similarly, if the truck speeds up, the gap will move to the rear. Turning the SPEED knob slightly clockwise will decrease the delay and move the gap back to the reflector.

## TROUBLESHOOTING

PROBLEM	CORRECTION
1. No lamps illuminate.	Verify that 12v is turned on and available at the R10B terminal block  Check fuse on circuit board.
2. No guns come on	Check fuse on circuit board. Check to be sure that there is 12 volts at the CONTROL terminals in the R10B.
3. Guns don't skip markers	If the SENSE lamp doesn't flash on when approaching a reflector, reset the BALANCE control slightly clockwise. If the sense light stays on between reflectors, adjust the BALANCE control slightly counterclockwise.  If the SKIP lamp flashes and the guns fail to skip, be sure that the switch is set to ON position..
4. Cannot adjust SENS or BALANCE control to turn SENSE lamp on or off.	Check for damaged (curbed) sensor head. Check head cable for broken wires. Perform continuity testing.

## CONTINUITY TESTS

### SENSOR HEAD WINDINGS (test at sensor head connector)

From:	To:	Read:
Pin A	Pin B	1-3 ohms
Pin C	Pin D	1-3 ohms
Pin E	Pin F	<1 ohm

Readings higher than specified indicate a defective sensor head.

### SENSOR HEAD SHORTS (test at sensor head connector)

From:	To:	Read:
Pin A	Pin C	Open
Pin A	Pin E	Open
Pin C	Pin E	Open

Pin A	Pin G	Open
Pin C	Pin G	Open
Pin E	Pin G	Open

Readings lower than open circuit indicate a defective sensor head

#### CABLE CONTINUITY

The cable is straight wired from Pin A to Pin A, etc. Check continuity on all seven pins. Resistance should be nearly zero. Check for shorts between all combinations of pins, resistance should be near infinite.

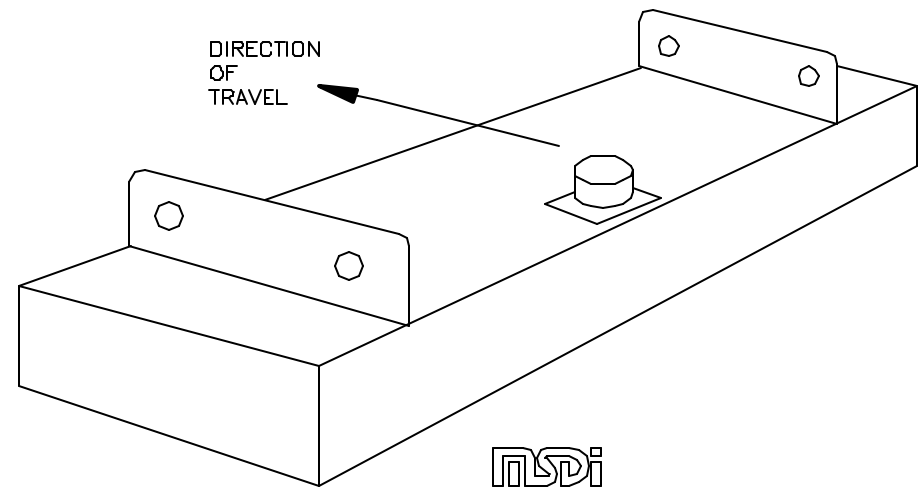
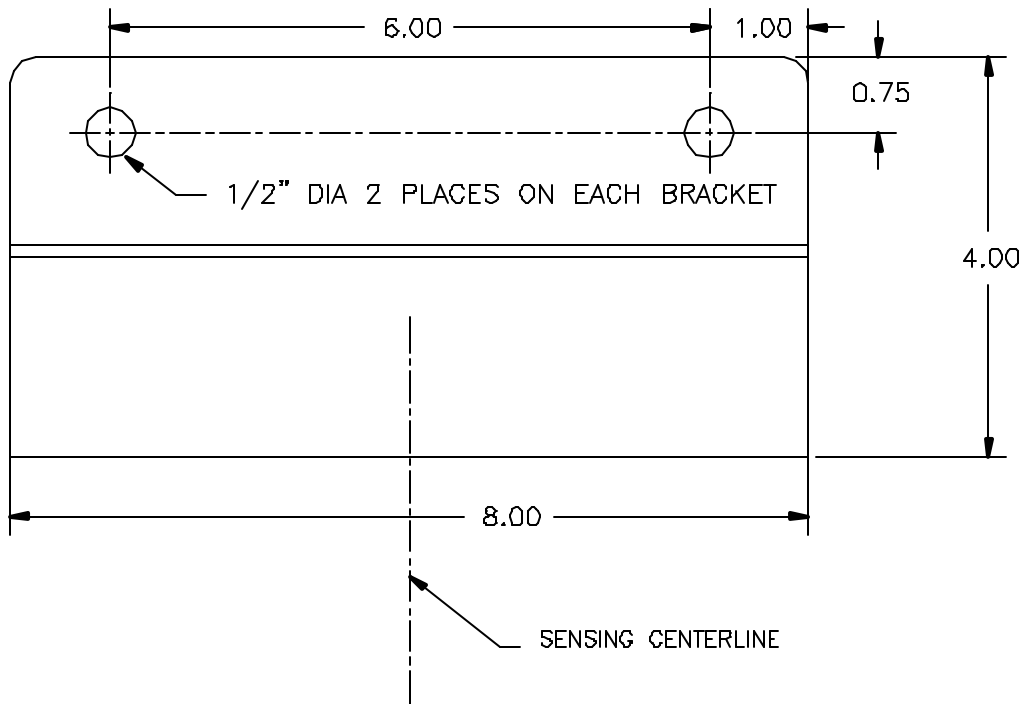
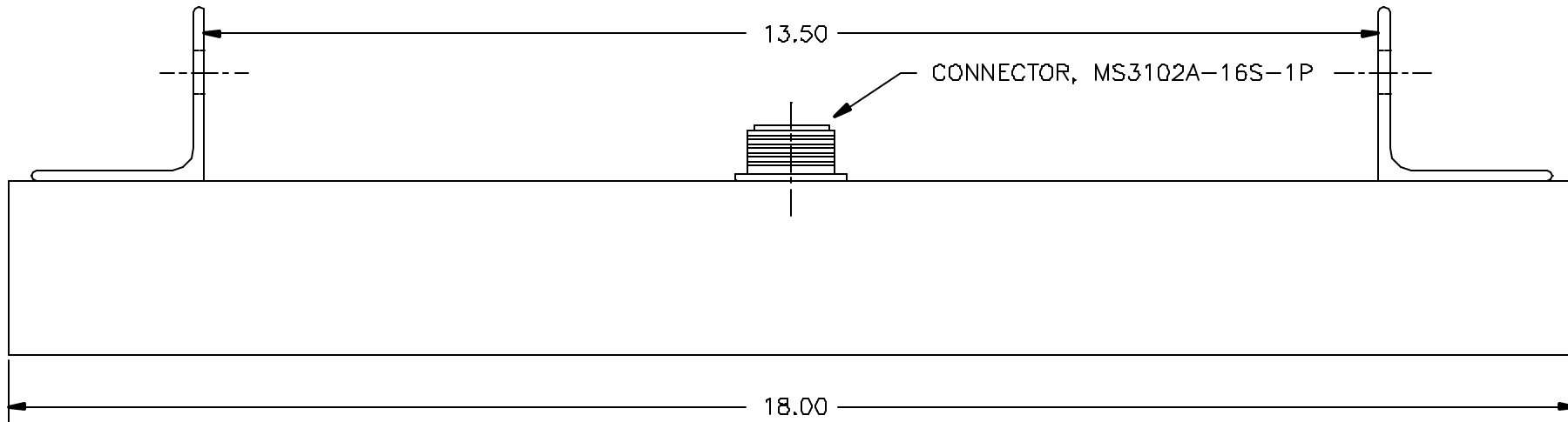

REFLECTOR SENSOR DIMENSIONS 18 INCH  
 USED ON MODEL R10 DETECTOR SYSTEM  
 1/15/92  
 WEIGHT: 15 POUNDS

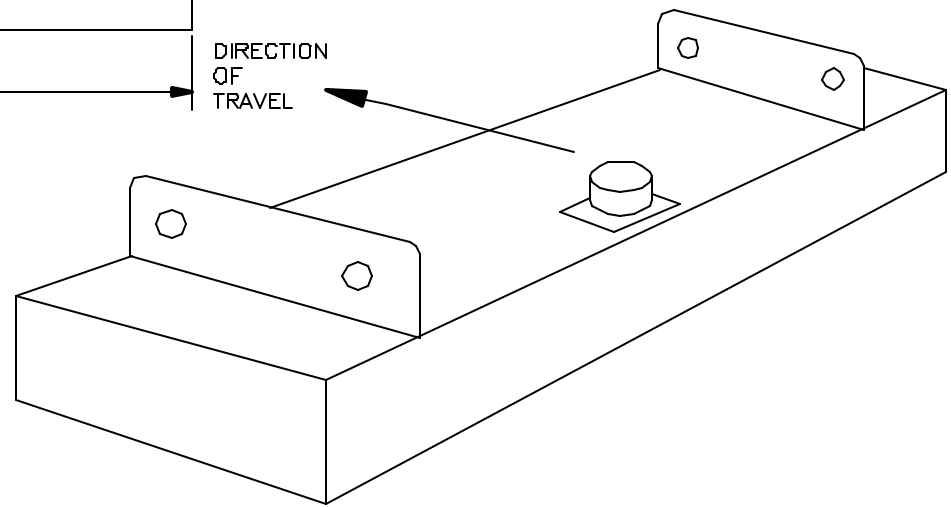
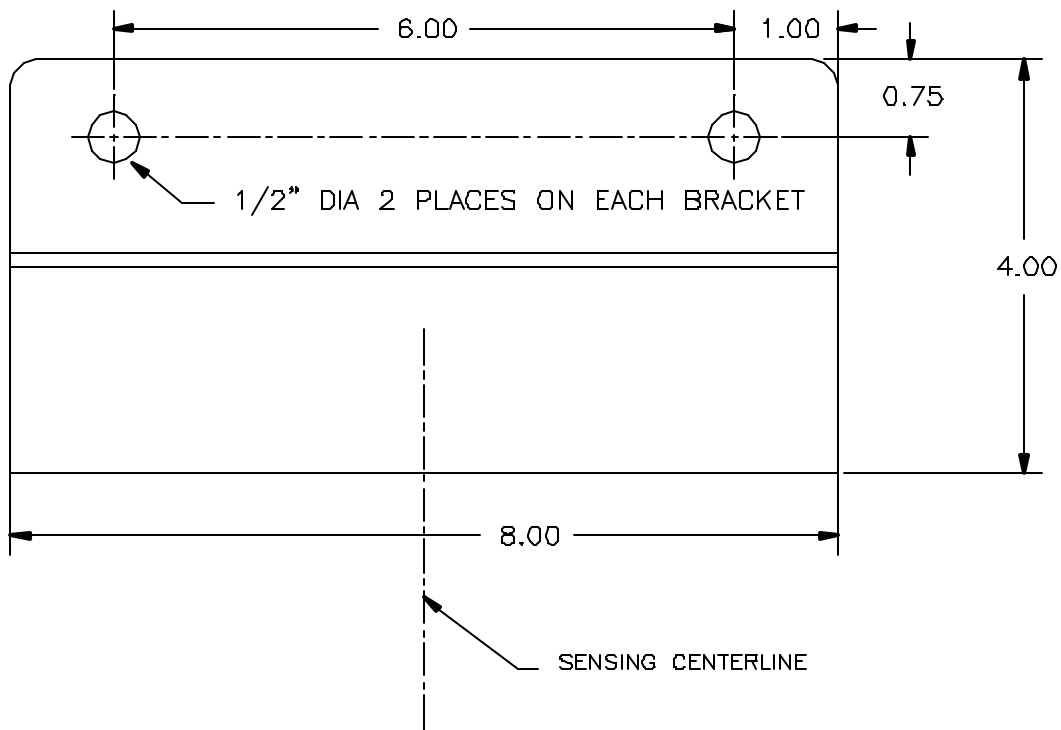
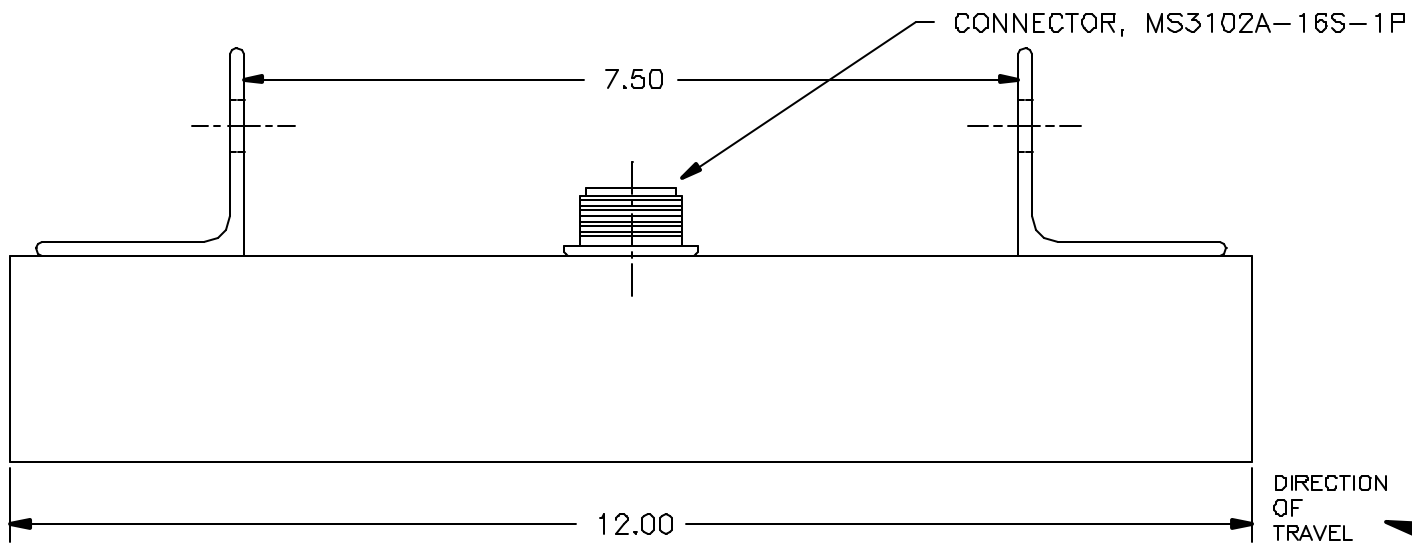

WEIGHT: 10 POUNDS



REFLECTOR SENSOR DIMENSIONS  
USED ON MODEL R10 12 INCH  
1/15/92

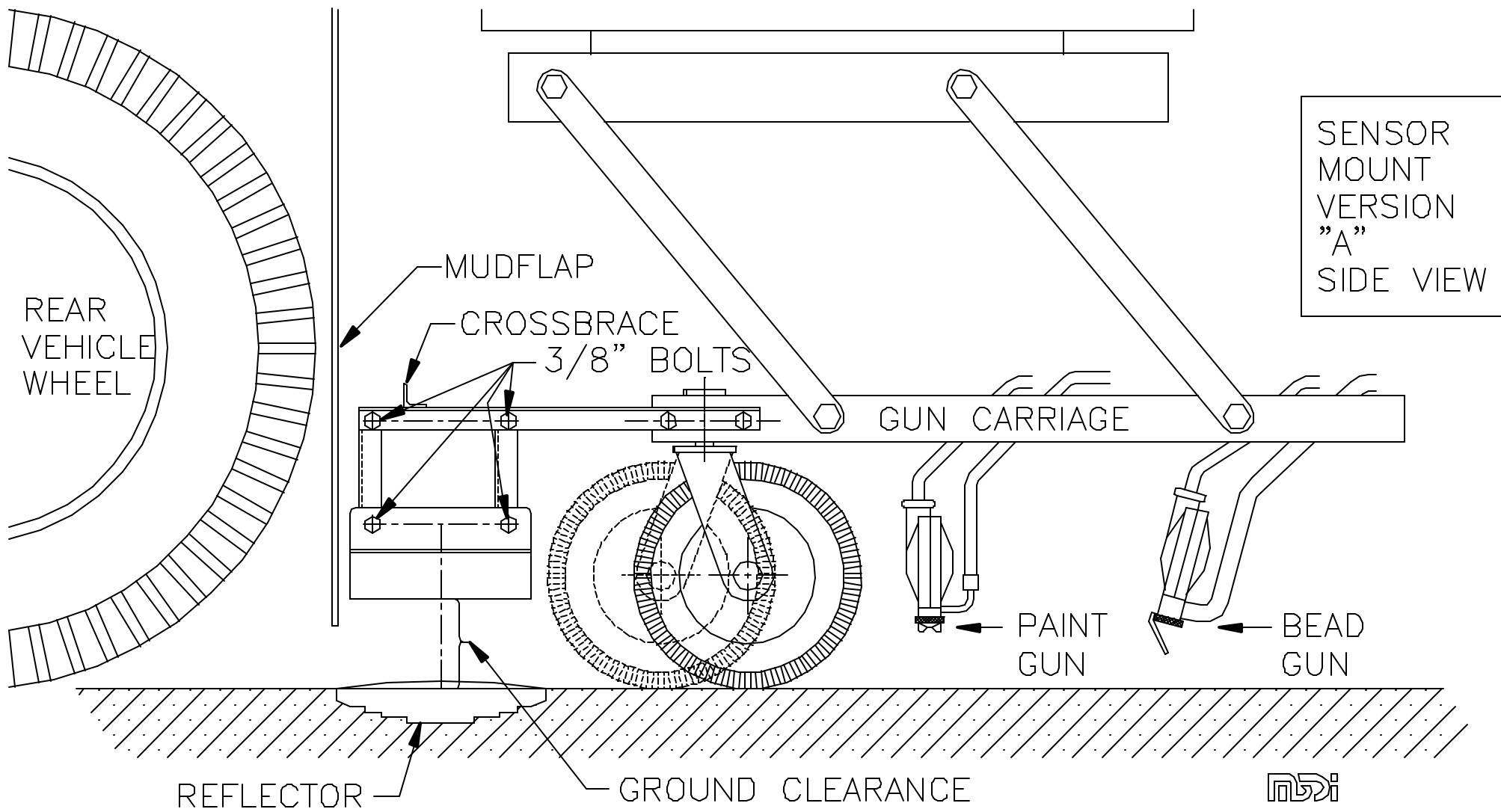

SENSOR MOUNT  
VERSION  
"A"  
SIDE VIEW

REAR  
VEHICLE  
WHEEL

MUDFLAP

CROSSBRACE  
3/8" BOLTS

GUN CARRIAGE

PAINT  
GUN

BEAD  
GUN

REFLECTOR

GROUND CLEARANCE



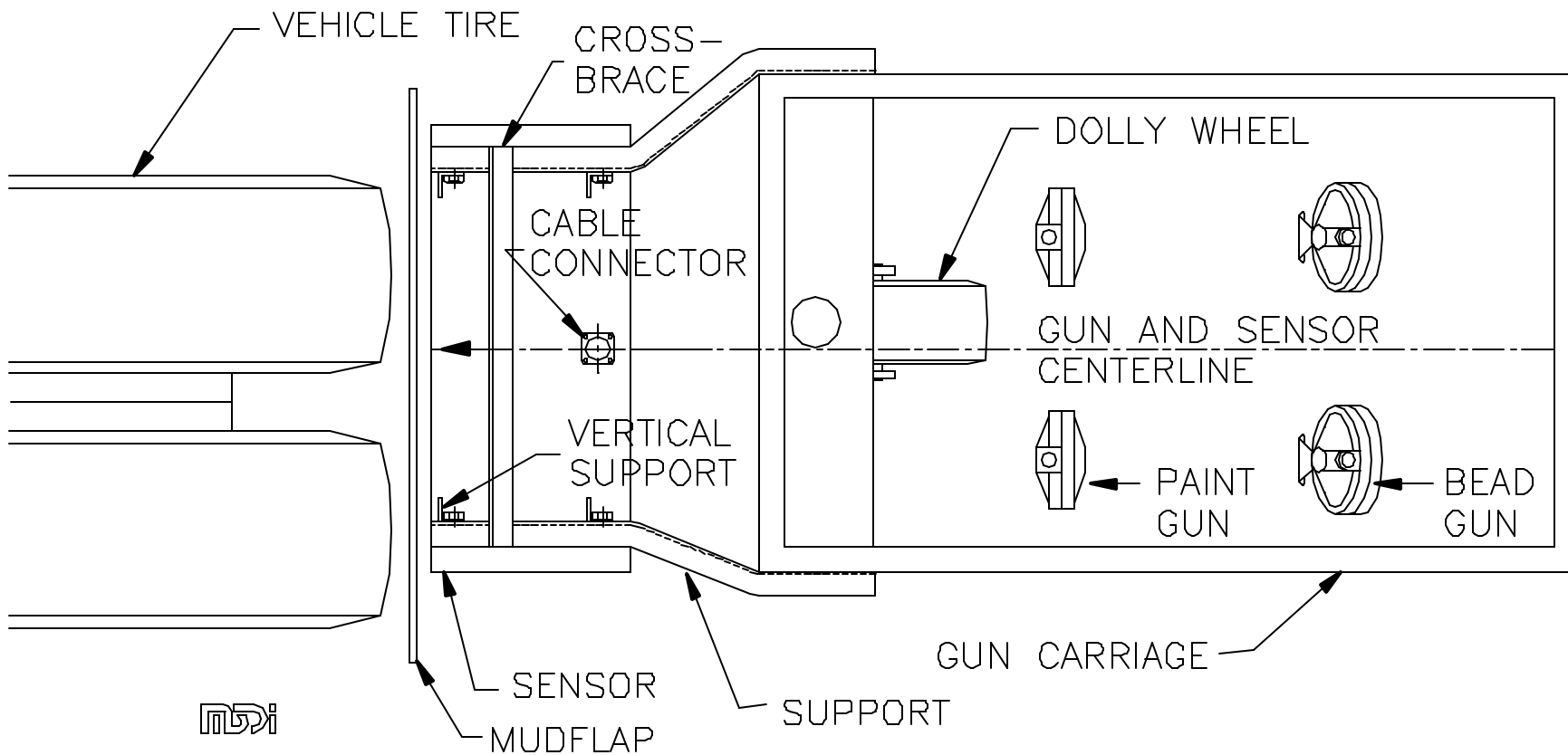

SENSOR MOUNT VERSION "A" TOP VIEW

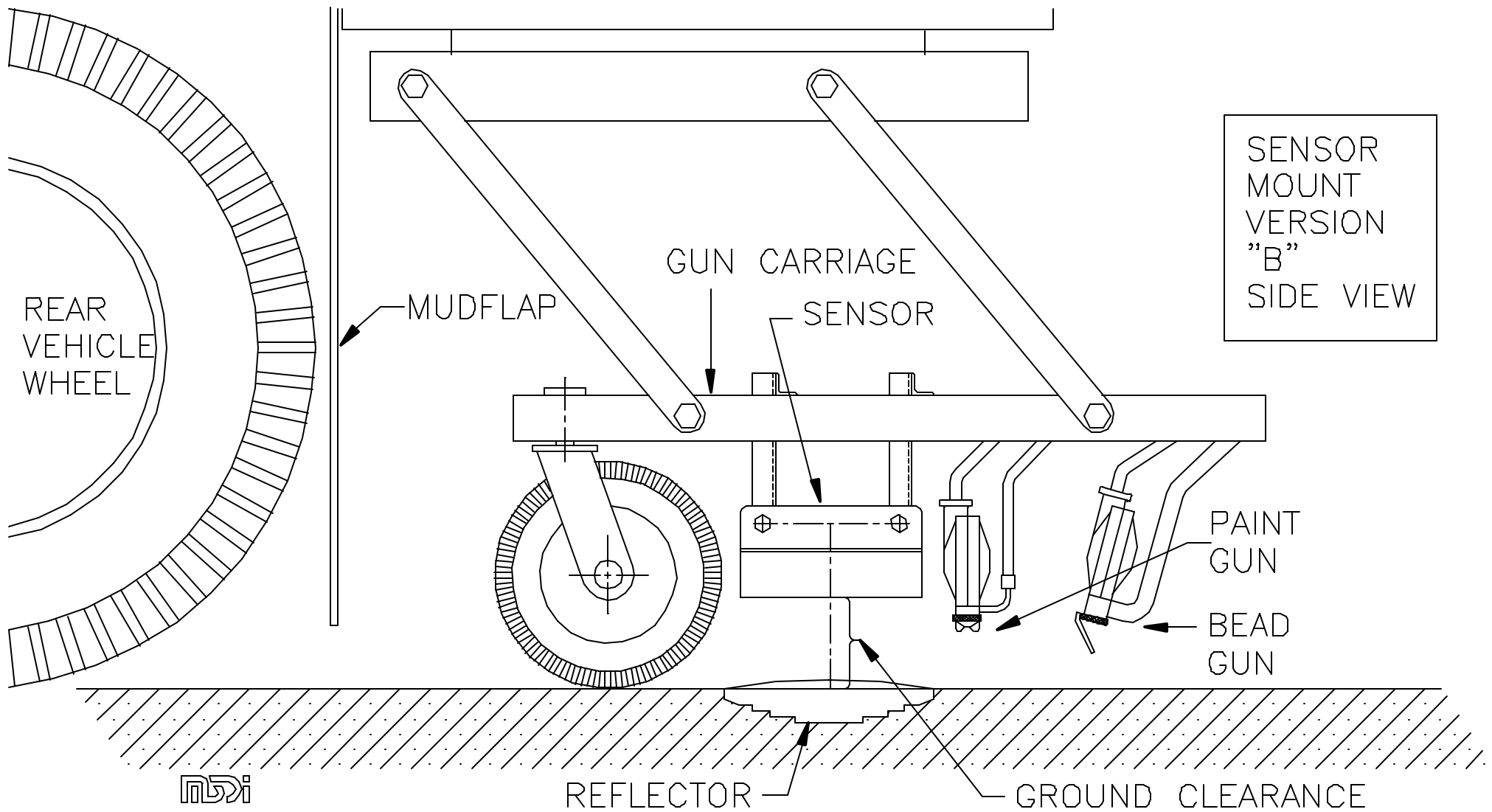

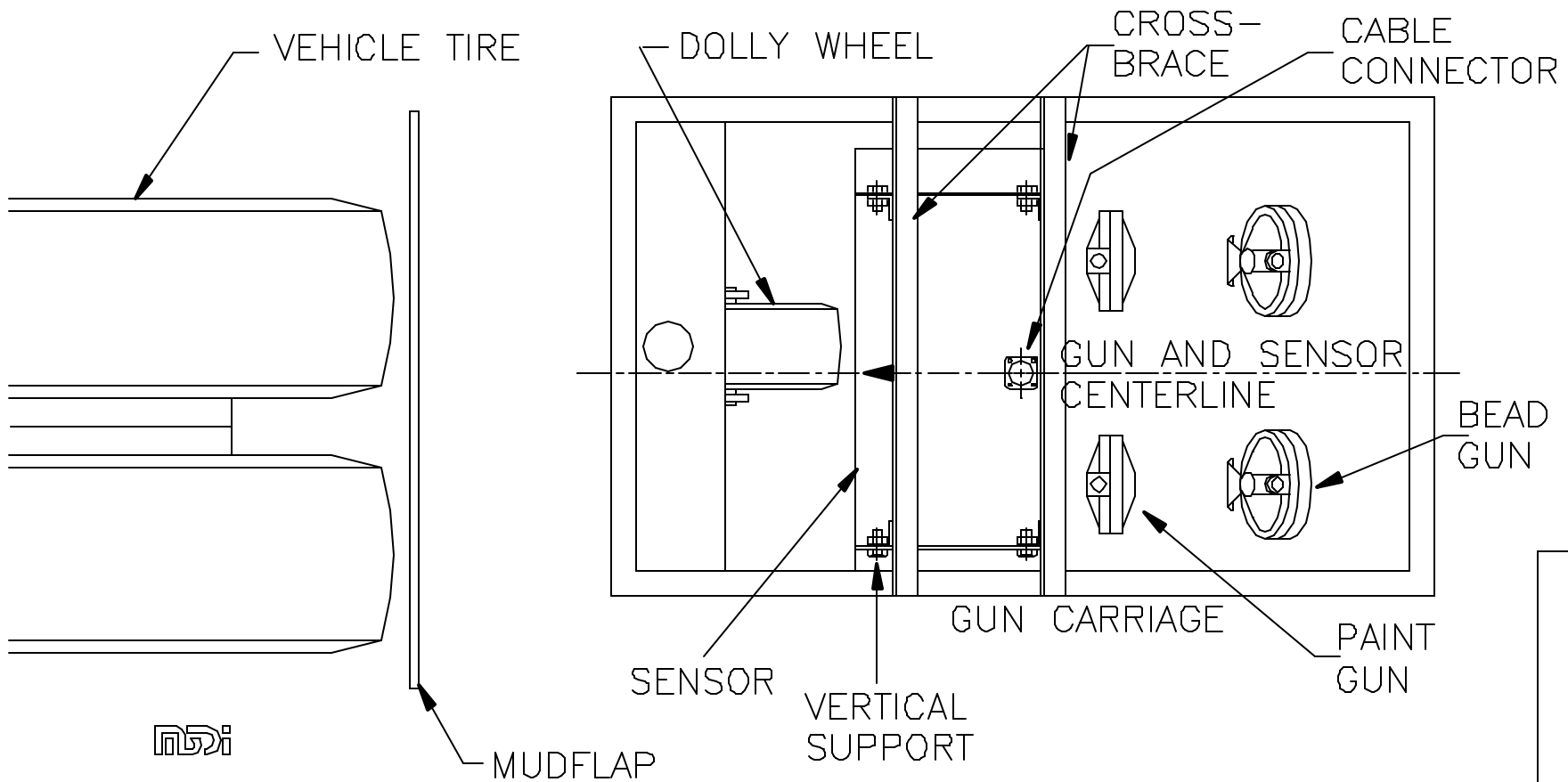

SENSOR  
 MOUNT  
 VERSION  
 "B"  
 TOP VIEW



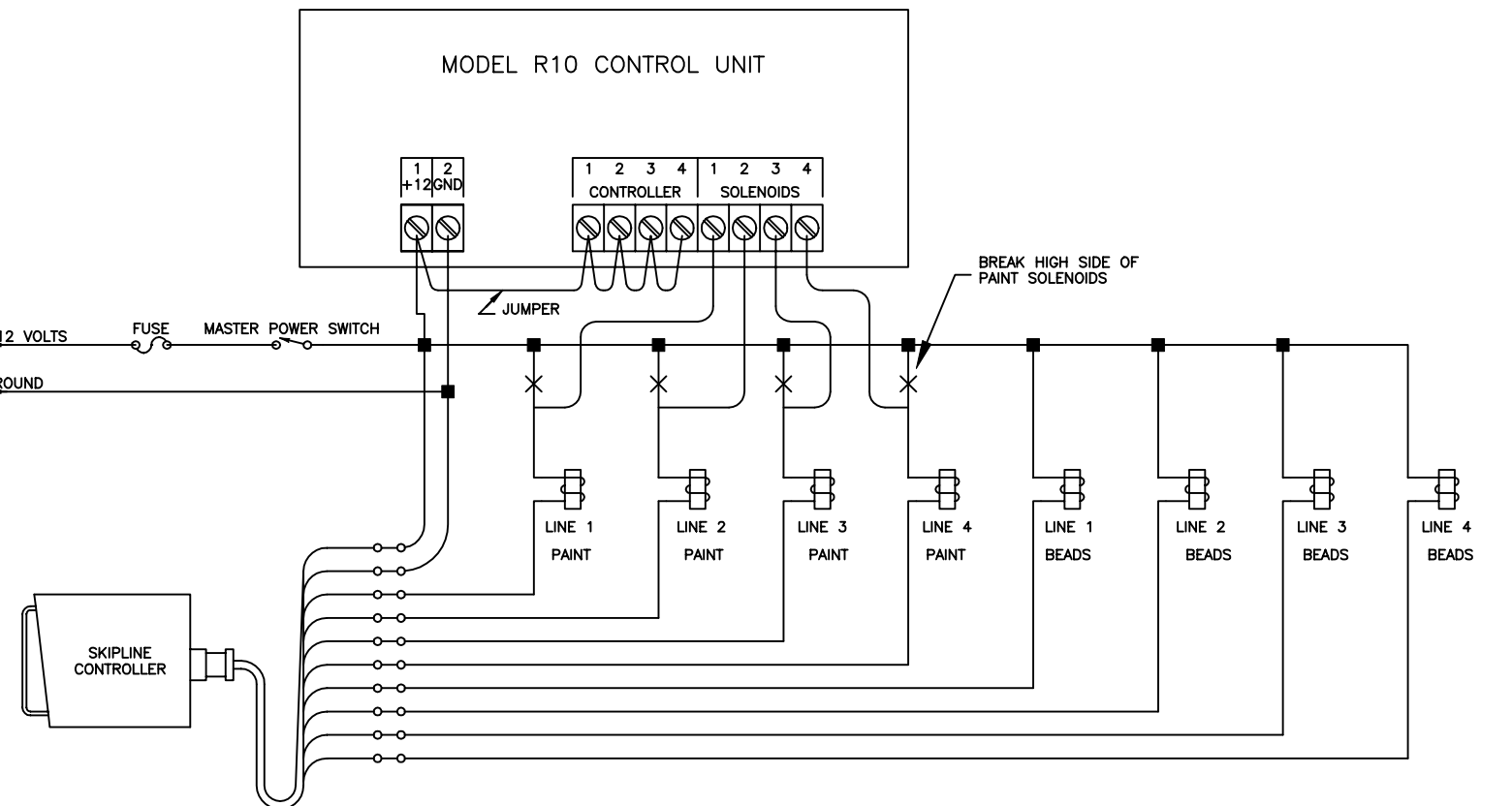
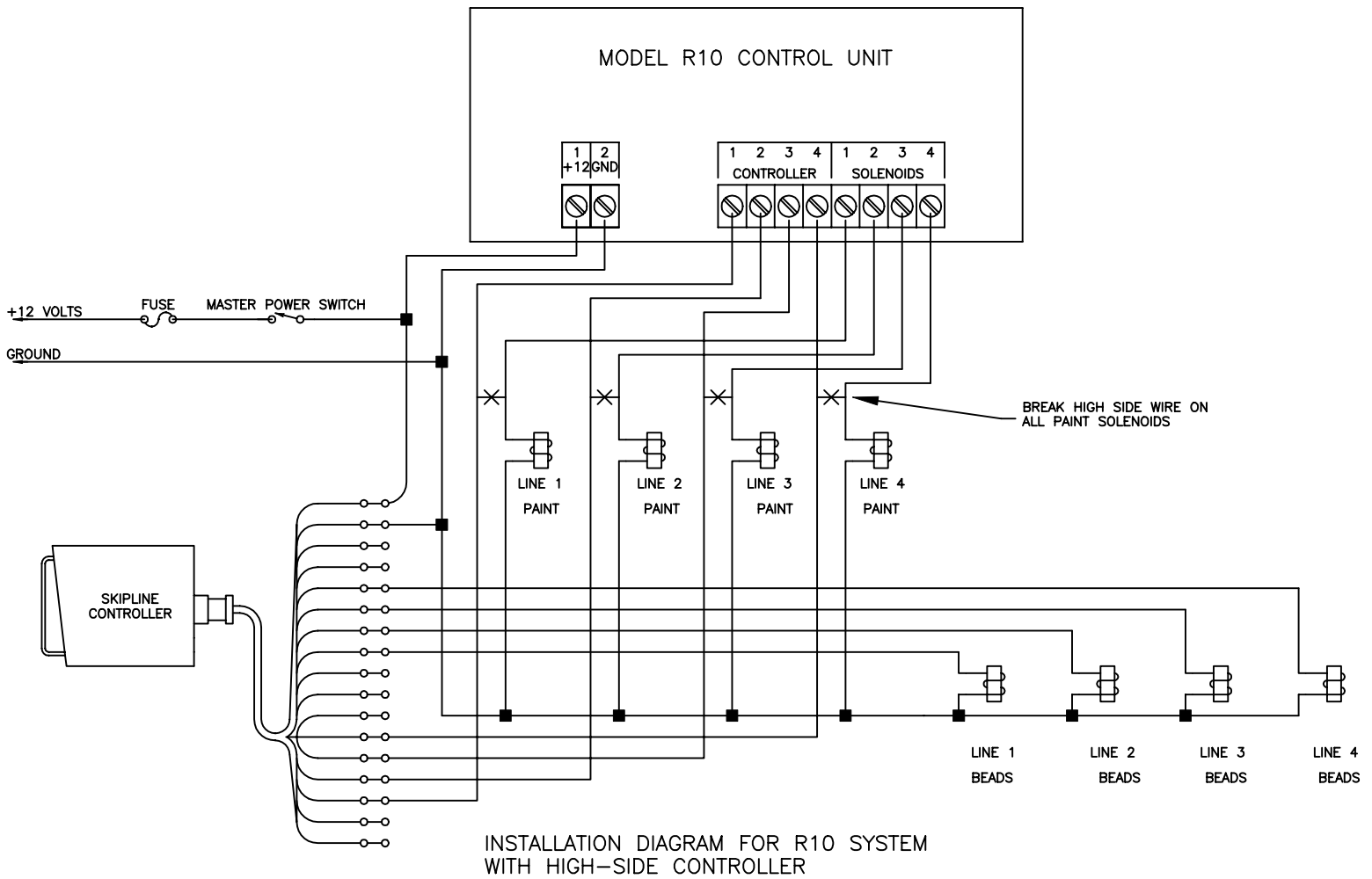

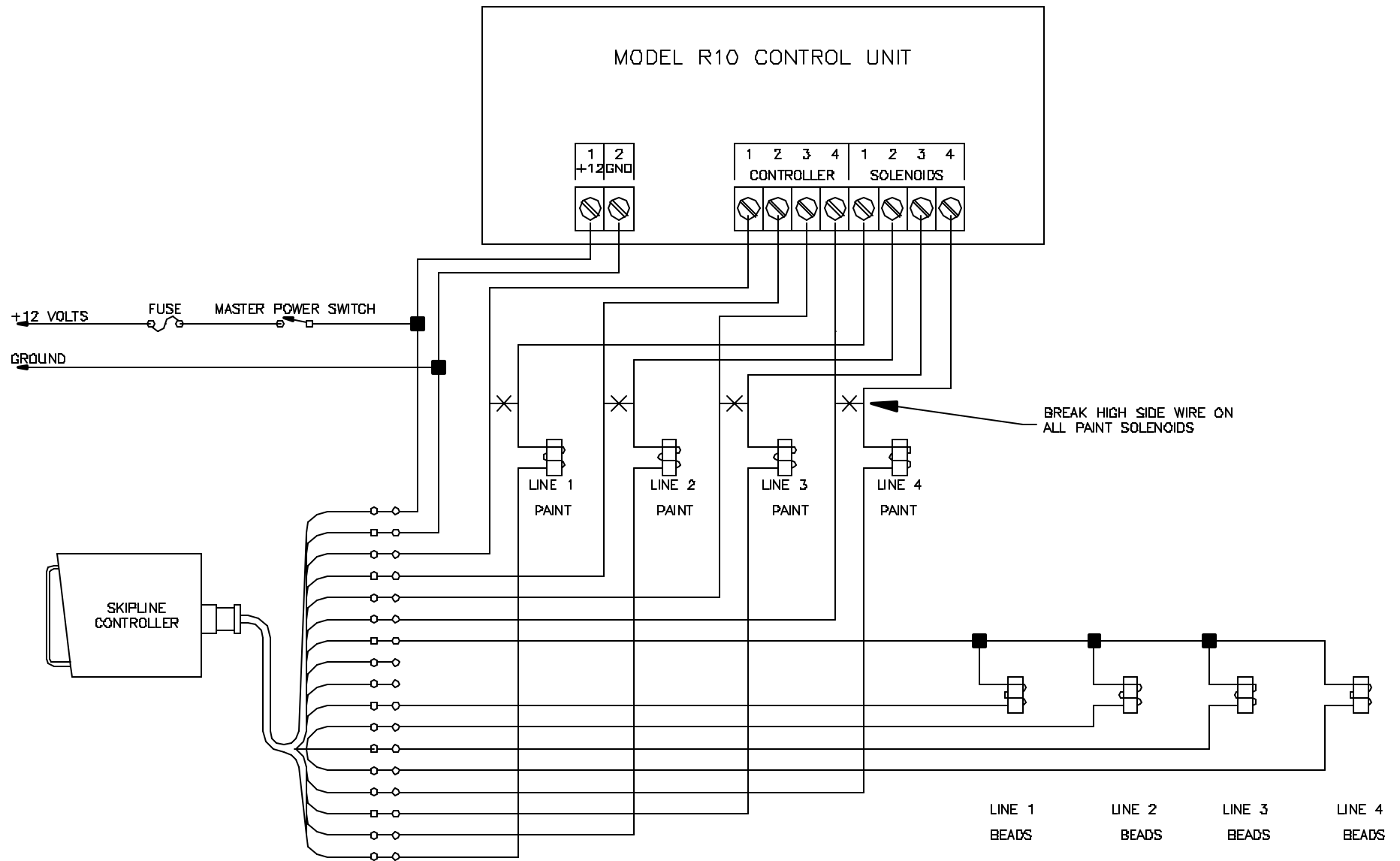

INSTALLATION DIAGRAM FOR R10 SYSTEM WITH BOTH HIGH AND LOW SIDE CONTROLLER

INSTALLATION THE R10 REFLECTOR DETECTOR  
with an  
MSDI SKIPLINE CONTROLLER

The R10 Reflector Detector works properly with the CS22A, CS33A and SC88B Skipline Controllers, except for the automatic Open Circuit sensing system in the controllers. It is necessary to install 820 ohm resistors from the +12 volt line to the paint solenoid leads on the MSDI controllers to disable the open circuit sensing.

Note that the installation of these resistors prevents the controllers from detecting open circuits. Likewise, the power transistors in the R10 may prevent the controllers from detecting short circuits. The fuse in the R10 will prevent damage in the event of a short circuit.

The bead guns short and open circuit sensors will continue to operate normally, as they are not connected to the R10 but remain directly connected to the controller.

The attached wiring diagram shows how to make the interconnections between the units. Be sure to use heavy (#16 or larger) wire to connect the R10 to the power source and ground as it draws several amperes in addition to the solenoid current.

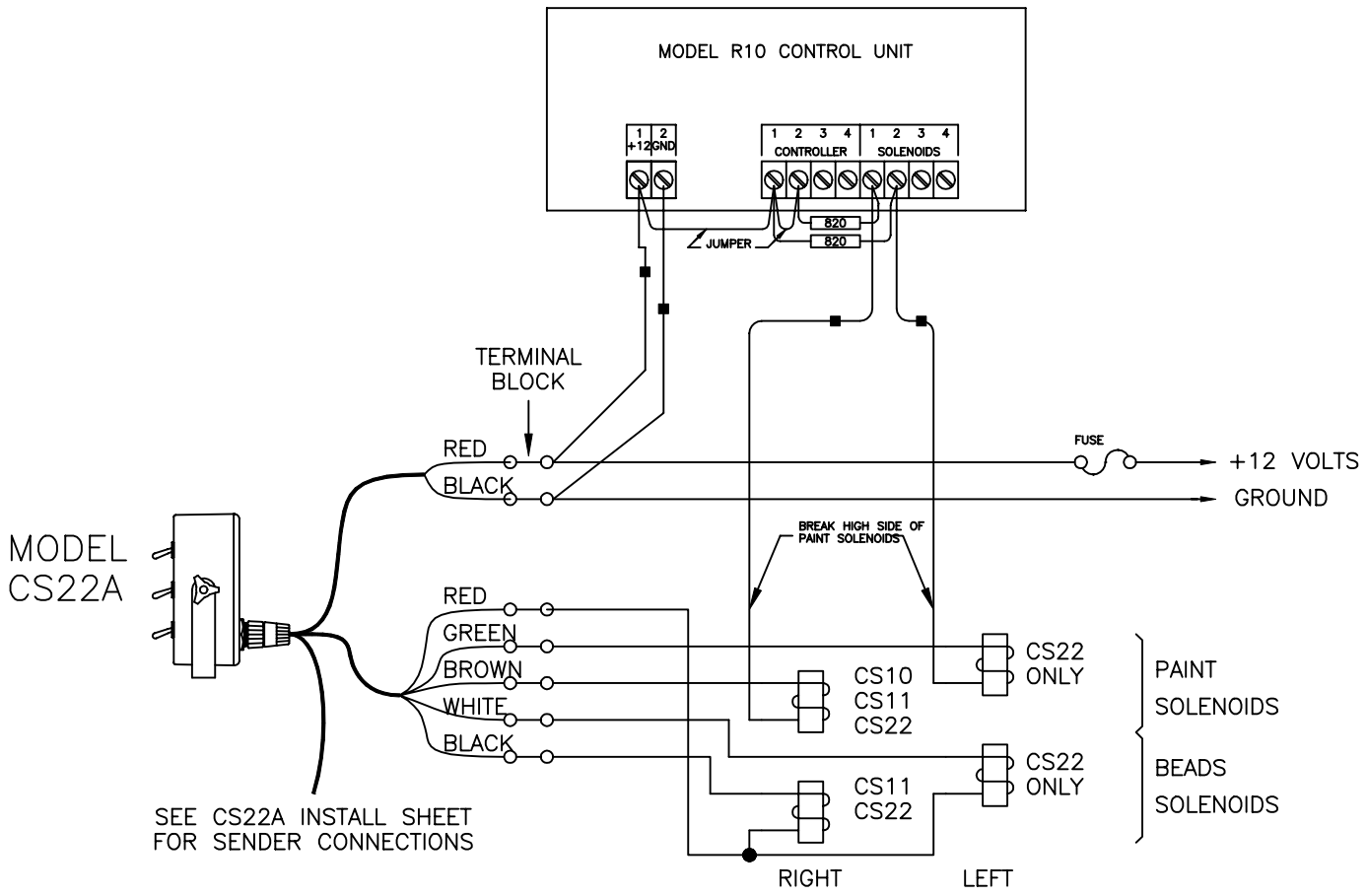
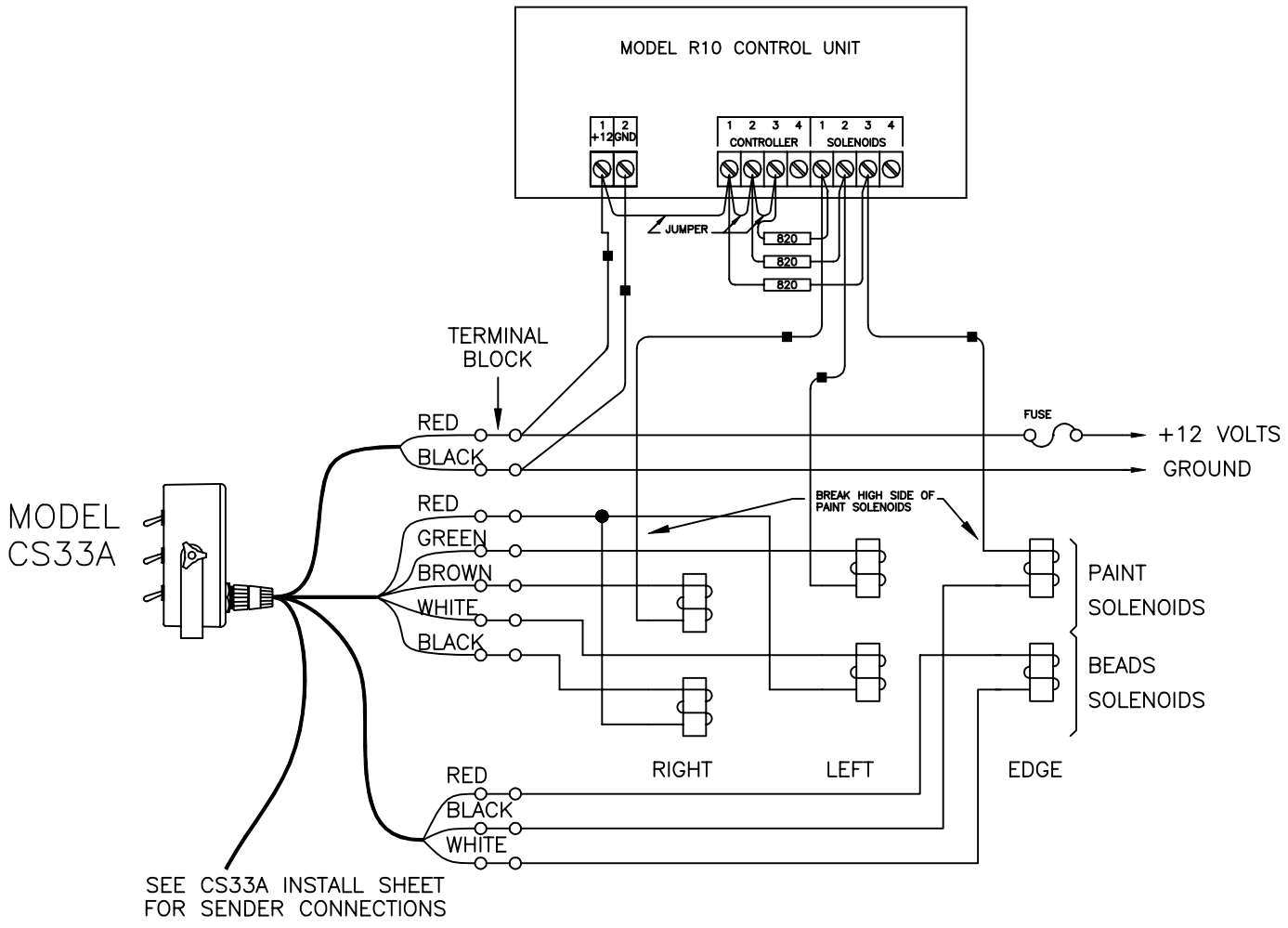

INSTALLATION DIAGRAM FOR CS22A/R10 COMBINATION

# Warranty

Products manufactured by MICRO SYSTEMS DEVELOPMENT INC. (MSDI) are warranted against defects in material and workmanship for a period of ONE YEAR from date of delivery. During the warranty period, MSDI will, at its option, either repair or replace products which prove to be defective. Defective equipment must be returned prepaid. Repaired equipment will be returned to purchaser shipping charges collect. Accessories supplied by MSDI but manufactured by others are covered by their respective manufacturers' warranties.

## LIMITATION OF WARRANTY

This warranty excludes normal consumables including, but not limited to, printer ribbons and paper. **Damage caused by Acts of God, improper application of the equipment, improper or reversed power supplies, or incorrect wiring is excluded from warranty coverage. Damage to R10 Sensor Heads is specifically excluded from this warranty.**

**Inasmuch as the application of this equipment is beyond the control of MSDI, all warranties as to performance, merchantability, or fitness for any particular purpose, whether expressed or implied, are hereby disclaimed. The proper application of this equipment is the sole responsibility of the user.**

**IN NO EVENT SHALL MSDI BE LIABLE FOR ANY DIRECT, INDIRECT, SPECIAL, INCIDENTAL OR CONSEQUENTIAL DAMAGES.**

The logo for Micro Systems Development, Inc. (MSDI) consists of the letters 'MSDI' in a bold, stylized, sans-serif font. The letters are black and have a slightly irregular, blocky appearance.

Micro Systems Development, Inc. 46 Marco Lane Dayton, Ohio 45458, USA